



150W Ku-Band Compact Outdoor 1:1 Redundant System

### DESCRIPTION

Teledyne Paradise Datacom's **Outdoor** series of redundant amplifier systems provide the highest degree of earth station redundancy and reliability. Based on Teledyne Paradise Datacom's family of rugged and robust SSPAs, these systems provide the highest MTBFs possible.

These systems can be configured in either 1:1 or 1:2 redundant configurations using any of the Teledyne Paradise Datacom family of Outdoor SSPAs. The RCP2-1100/1200 Redundant Controller provides an extremely user-friendly interface for complete monitor and control of the high power amplifiers in either 1:1 or 1:2 configurations.

The RCP front panel mimic display shows the on-line amplifiers and the current switch positions. Dedicated fault lights provide easy indication of system status. All RCP2-1X00 monitor and control is available locally, at the front panel LCD display, as well as remotely by the RS-232 or RS-485 interface ports.

### FEATURES

- System Output Power to:  
1000W S-Band;  
800W C-Band;  
800W X-Band;  
400W Ku-Band
- Universal Input, Power Factor Corrected Power Supply
- Output Power Monitoring
- Separate 1RU Redundant Controller or Controller-less configurations

### OPTIONS

- System Output Power Monitor
- Reflected Power Alarm
- L-Band Input Operation
- Cold Standby Amplifier Operation
- Custom Configurations

[Request A Quote](#)



### High Power Outdoor Output Power Levels

|          |              |
|----------|--------------|
| S-Band:  | 500W - 1000W |
| C-Band:  | 400W - 800W  |
| X-Band:  | 350W - 800W  |
| Ku-Band: | 200W - 500W  |

### Compact Outdoor Output Power Levels

|          |            |
|----------|------------|
| S-Band:  | 50W - 500W |
| C-Band:  | 30W - 400W |
| X-Band:  | 25W - 400W |
| Ku-Band: | 10W - 250W |

### System Output Power Capacity

Due to residual losses inherent in redundant system configurations (waveguide bends; switch and coupler losses), reduce the typical output power specification of a single amplifier by approximately 0.2 dB for 1:1 and by 0.4 dB for 1:2 systems.

For example, a single thread 100W Ku-Band Compact Outdoor SSPA has a typical saturated output power of 50.0 dB (100W).

Placing two of the above amplifiers in a 1:1 redundant system configuration would reduce the typical system saturated output by 0.2 dB to 49.8 dB (96W).

Placing three of the above amplifiers in a 1:2 redundant system configuration would reduce the typical system saturated output by 0.4 dB to 49.6 dB (91W).

Actual system losses will vary based on the system options.

### General Specifications

| PARAMETER                      | NOTES  | LIMITS             | UNITS               |
|--------------------------------|--|--------------------|---------------------|
| Gain                           | minimum  | 70                 | dB                  |
| Gain Flatness                  | full band (all except Extended C-Band)             | ± 1.0              | dB                  |
|                                | Extended C-Band units                              | ± 1.5              | dB                  |
| Gain Slope                     | per 40 MHz (C-, X-, Ku-Bands)                      | ± 0.3              | dB/40 MHz           |
|                                | per 10 MHz (S-Band)                                | ± 0.2              | dB/10 MHz           |
| Gain Variation vs. Temperature | -40 to +60°C                                       | ± 1.0              | dB                  |
| Gain Stability                 | at constant temperature                            | ± 0.25             | dB/24 hours         |
| Gain Adjustment                | 0.1 dB resolution                                  | 20                 | dB                  |
| Intermodulation Distortion     | 3 dB back off relative to P <sub>1dB</sub>         | -25                | dBc                 |
| AM/PM Conversion               | (@ rated P <sub>1dB</sub> )                        | 3.5                | °/dB                |
|                                | (@P <sub>1dB</sub> - 3 dB)                         | 1.0                | °/dB                |
| Spurious                       | (@ rated P <sub>1dB</sub> )                        | -65                | dBc                 |
| Harmonics                      | (@ rated P <sub>1dB</sub> - 3 dB) (C-,X-,Ku-bands) | -50                | dBc                 |
|                                | (@ rated P <sub>1dB</sub> - 3 dB) (S-band)         | -30                | dBc                 |
| Input/Output VSWR              | (Extended C-Band with 1.3:1 VSWR option)           | 1.50:1<br>1.30:1   |                     |
| Noise Figure                   | at maximum gain (C-,X-,Ku-bands)                   | 10                 | dB                  |
|                                | at maximum gain (S-band)                           | 8                  | dB                  |
| Group Delay                    | Linear   | 0.01               | ns/MHz              |
| (per 40 MHz segment)           | Parabolic  | 0.003              | ns/MHz <sup>2</sup> |
|                                | Ripple   | 1.0                | ns p-p              |
| Transmit Band Noise            | TX Band  | -75                | dBW/4 KHz           |
| Output Power Density           | RX Band (C- or Ku-bands)                           | -150               | dBW/4 KHz           |
|                                | RX Band (X-Band)                                   | -100               | dBW/4 KHz           |
|                                | RX Band (S-Band)                                   | See options        |                     |
| Receive Band Noise             | S-Band, with optional filter                       | -155               | dBW/4 KHz           |
| Output Power Density           | S-Band, without optional filter                    | -95                | dBW/4 KHz           |
| Residual AM Noise              | 0 - 10 KHz   | -45                | dBc                 |
|                                | 10 KHz - 500 KHz                                   | -20 (1.25 + log F) | dBc                 |
|                                | 500 KHz - 1 MHz                                    | -80                | dBc                 |
| Phase Noise                    | Offset frequency from carrier                      |                    |                     |
|                                | 10 Hz  | -90                | dBc/Hz              |
|                                | 100 Hz   | -100               | dBc/Hz              |
|                                | 1 KHz  | -110               | dBc/Hz              |
|                                | 10 KHz   | -120               | dBc/Hz              |
|                                | 100 KHz  | -125               | dBc/Hz              |
|                                | 1 MHz  | -130               | dBc/Hz              |

### Environmental

|                       |            |            |    |
|-----------------------|------------|------------|----|
| Operating Temperature | Ambient    | -40 to +60 | °C |
| Relative Humidity     | condensing | 100        | %  |
| Cooling System        | Integrated | Forced air |    |

### Mechanical

|                                    |                                       |  |                    |
|------------------------------------|---------------------------------------|--|--------------------|
| Size, High Power Outdoor, single   | width X length X height               | 16.5 X 27.5 X 9.335<br>419 X 699 X 238 | inches<br>mm       |
| Size, Compact Outdoor, single      | width X length X height               | 10.0 X 19.5 X 6.50<br>254 X 495 X 165  | inches<br>mm       |
| Weight, High Power Outdoor, single |                                       | 100 (45.5)                             | lbs. (kg)          |
| Weight, Compact Outdoor, single    | Base unit (<200W S/C-bands; <100W Ku) | 36 (16.4) ± 3%                         | lbs. (kg)          |
|                                    | Base unit (≥200W S/C-bands; ≥100W Ku) | 44 (20.0) ± 3%                         | lbs. (kg)          |
|                                    | Base unit (<200W X-Band)              | 46.7 (21.1) ± 3%                       | lbs. (kg)          |
|                                    | Base unit (≥200W X-Band)              | 54.9 (25.0) ± 3%                       | lbs. (kg)          |
|                                    | With Internal zBUC                    | +1.7 (0.8)                             | lbs. (kg)          |
| Finish                             |                                       | Paint                                  | White; powder coat |

### L-Band Operation

Teledyne Paradise Datacom amplifiers are available with an integrated L-Band Block Up Converter. L-Band units utilize Teledyne Paradise Datacom's proprietary zBUC technology. The addition of a zBUC<sup>®</sup> converter to the SSPA typically increases the gain by 2-4 dB. The advantages of zBUC technology include:

- zBUC converter can detect and switch to an externally supplied reference.
- Optional internal high stability (10MHz) reference.
- zBUC converter can lock to an externally supplied reference of 5, 10, 20, 25, or 50 MHz without modification.
- zBUC converter can accept a wide range of external reference power (-10 to +5 dBm)
- zBUC converter can accept FSK monitor and control signal via the IFL for complete amplifier remote control.

### Available Frequency Plans

| Band | Frequency Band    | IF Input       | LO Frequency | RF Output         | Gain Change |
|------|-------------------|----------------|--------------|-------------------|-------------|
| C    | Standard C-Band   | 950 - 1525 MHz | 4.900 GHz    | 5.850 - 6.425 GHz | 0-4 dB      |
| C    | Extended C-Band   | 950 - 1825 MHz | 4.900 GHz    | 5.850 - 6.725 GHz | 0-4 dB      |
| C    | Palapa Band       | 950 - 1250 MHz | 5.475 GHz    | 6.425 - 6.725 GHz | 0-4 dB      |
| C    | Insat Band        | 950 - 1250 MHz | 5.775 GHz    | 6.725 - 7.025 GHz | 0-4 dB      |
| C    | Extended C-Band 2 | 950 - 1675 MHz | 4.800 GHz    | 5.750 - 6.475 GHz | 0-4 dB      |
| C    | Low C-Band        | 840 - 1000 MHz | 4.250 GHz    | 5.090 - 5.250 GHz | 0-4 dB      |
| X    | Standard X-Band   | 950 - 1450 MHz | 6.950 GHz    | 7.900 - 8.400 GHz | 0-2 dB      |
| Ku   | Standard Ku-Band  | 950 - 1450 MHz | 13.050 GHz   | 14.00 - 14.50 GHz | 0-2 dB      |
| Ku   | Extended Ku-Band  | 950 - 1700 MHz | 12.800 GHz   | 13.75 - 14.50 GHz | 0-2 dB      |

### Electrical Specifications for Outdoor SSPA with ZBUC converter

| PARAMETER                 | NOTES  | LIMITS                 |                      |                      |                       | UNITS     |
|---------------------------|--|------------------------|----------------------|----------------------|-----------------------|-----------|
| Gain                      | Nominal setting                                      | 75                     |                      |                      |                       | dB        |
| Gain Flatness             | full band (C-,X-,Ku-bands)                           | ± 2.0                  |                      |                      |                       | dB        |
| Gain Slope                | per 40 MHz (C-,X-,Ku-bands)                          | ± 0.5                  |                      |                      |                       | dB/40 MHz |
| Gain Adjusted Range       |  | 20                     |                      |                      |                       | dB        |
|                           | Typical C-Band Adj. Range                            | 60 - 80                |                      |                      |                       | dB        |
|                           | Typical Ku-Band Adj. Range                           | 57 - 77                |                      |                      |                       | dB        |
| Gain Stability            | -40 to +60 °C  | ±1.5                   |                      |                      |                       | dB        |
| Phase Noise               | Offset frequency from carrier                        | <u>Absolute max.</u>   | <u>C-band (typ.)</u> | <u>X-band (typ.)</u> | <u>Ku-band (typ.)</u> |           |
|                           | 10 Hz  | -30                    | -60                  | -60                  | -50                   | dBc/Hz    |
|                           | 100 Hz   | -60                    | -80                  | -75                  | -65                   | dBc/Hz    |
|                           | 1 KHz  | -70                    | -80                  | -75                  | -72                   | dBc/Hz    |
|                           | 10 KHz   | -80                    | -85                  | -100                 | -90                   | dBc/Hz    |
|                           | 100 KHz  | -90                    | -120                 | -110                 | -110                  | dBc/Hz    |
|                           | 1 MHz  | -90                    | -125                 | -122                 | -120                  | dBc/Hz    |
| Spurious                  | In-Band Signal Related (C-/Ku-Band)                  |                        |                      |                      |                       | dBc       |
|                           | (Extended C-Band)                                    |                        |                      |                      |                       | dBc       |
|                           | Close to Carrier Spurious (≤ 20 MHz)                 |                        |                      |                      |                       | dBc       |
|                           | Local Oscillator                                     |                        |                      |                      |                       | dBm       |
| Noise Figure              | At 75 dB gain setting                                | 20                     |                      |                      |                       | dB        |
| Input VSWR                | L-Band   | 1.5 : 1                |                      |                      |                       |           |
| Internal Reference Option | Aging per day (after 30 days)                        | ± 1 • 10 <sup>-9</sup> |                      |                      |                       |           |
|                           | Aging per year (after 30 days)                       | ± 6 • 10 <sup>-8</sup> |                      |                      |                       |           |
|                           | Reference Stability over Temperature (-20 to +85 °C) | ± 3 • 10 <sup>-8</sup> |                      |                      |                       |           |

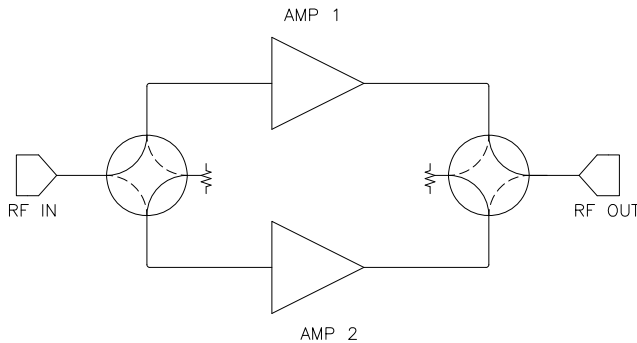

**1:1 Redundant HPA System**

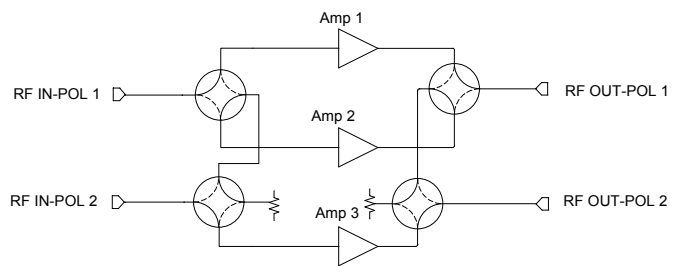

**1:2 Redundant HPA System**

Teledyne Paradise Datacom's Outdoor Packaged Redundant Systems are designed with built-in redundancy for 1:1 systems. All system-level monitor and control is internal and no separate controller is required, although an optional RCP2-1100 1:1 Redundant System Controller is available. Either Ethernet or RS-485 communications are selectable for user monitor and control. All 1:2 redundant systems require a separate RCP2-1200 Redundant System Controller.

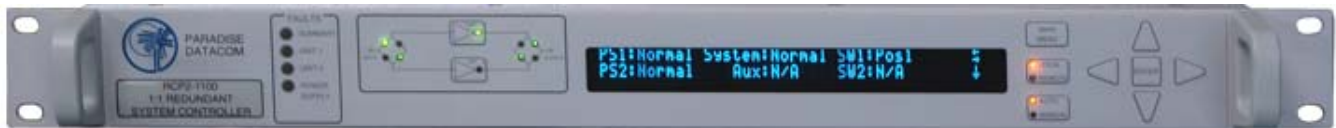

**RCP2-1100 1:1 Redundant System Controller**

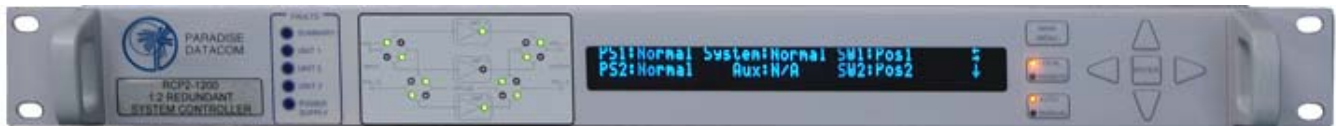

**RCP2-1200 1:2 Redundant System Controller**

The RCP2-1200 1:2 Redundant System Controller is the heart of the 1:2 redundant system. It provides an extremely user friendly interface for complete monitor and control of the high power amplifiers. The front panel mimic display shows the on-line amplifiers and the current switch positions. Dedicated fault lights are provided for easy indication of system status.

All Redundant System Controller monitor and control is available locally, at the front panel LCD display, as well as remotely by the RS-232, RS-485 or Ethernet interface ports. Audible alarms and a full compliment of parallel I/O signal are available at the rear panel.

### Outline Drawing, 1:1 Ku-Band High Power Outdoor SSPA System with RCP2-1100

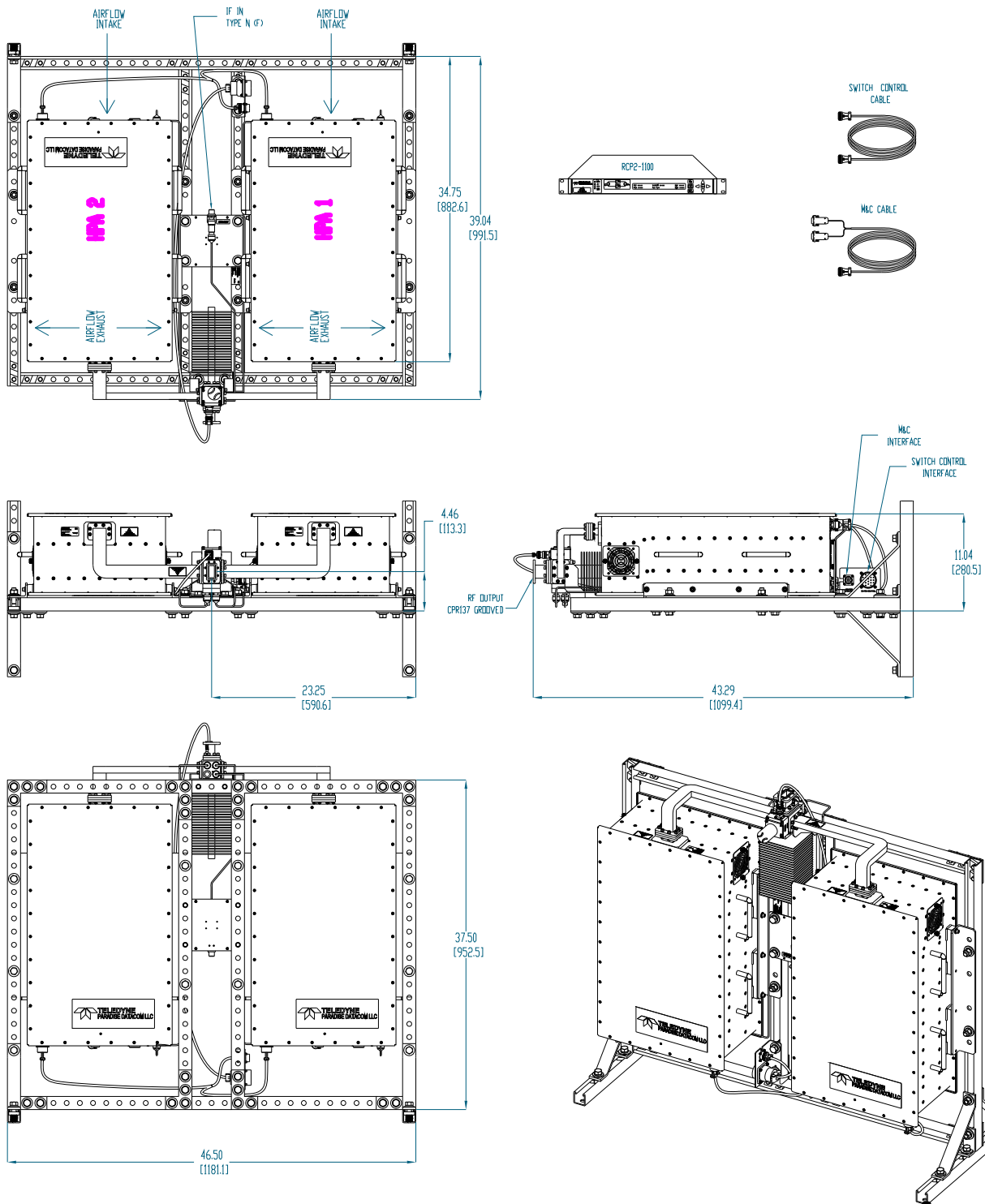

### Outline Drawing, 1:2 C-Band Compact Outdoor SSPA System with RCP2-1200

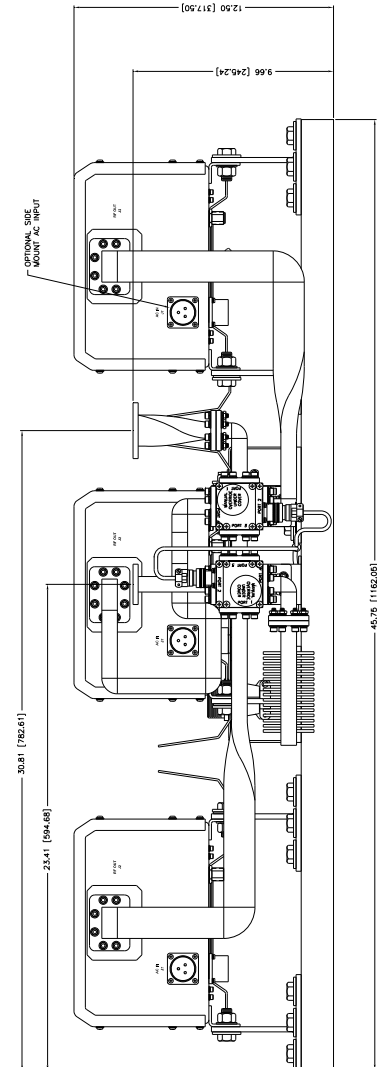
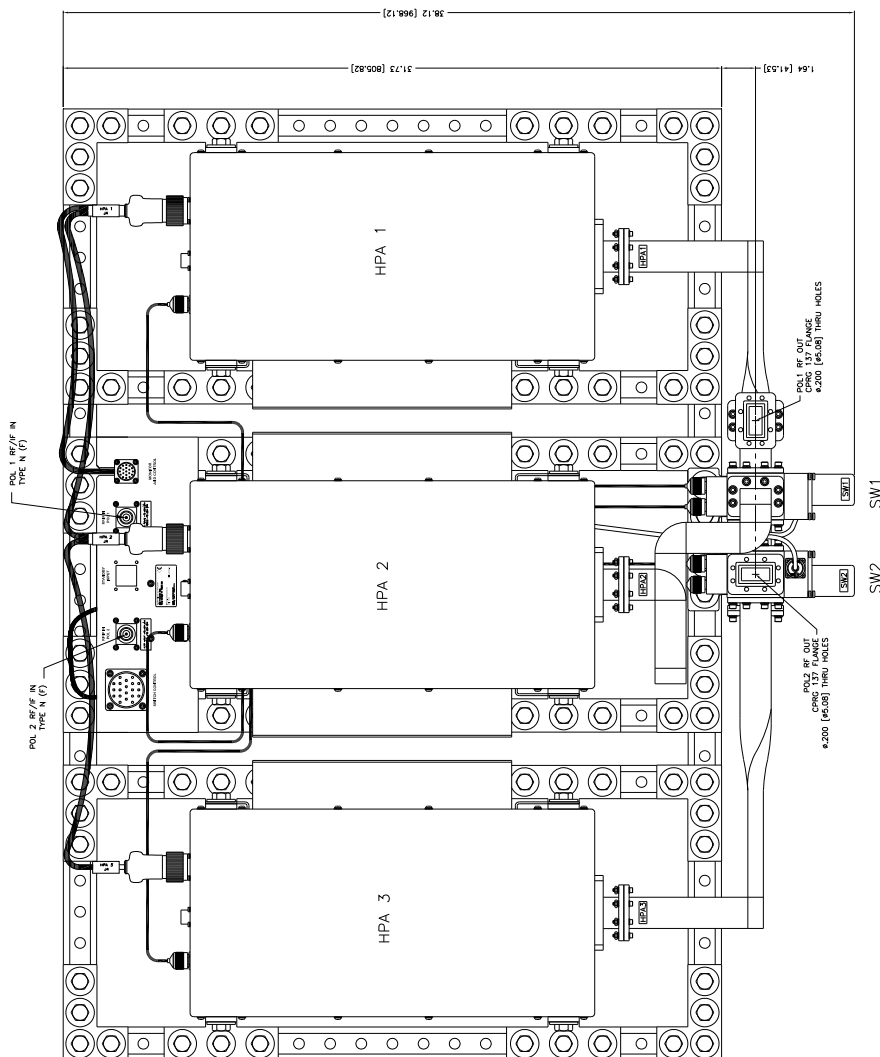
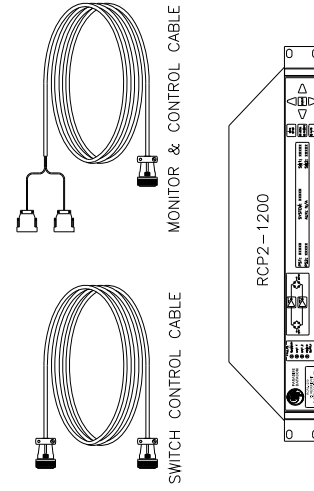
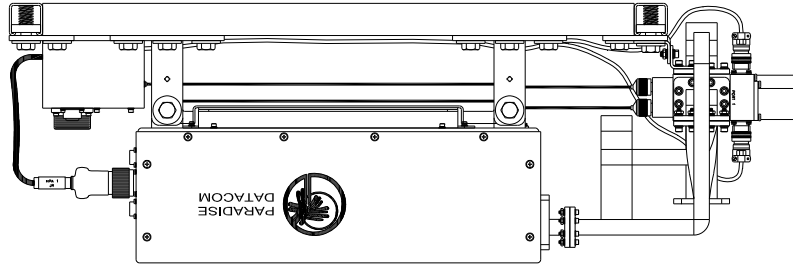

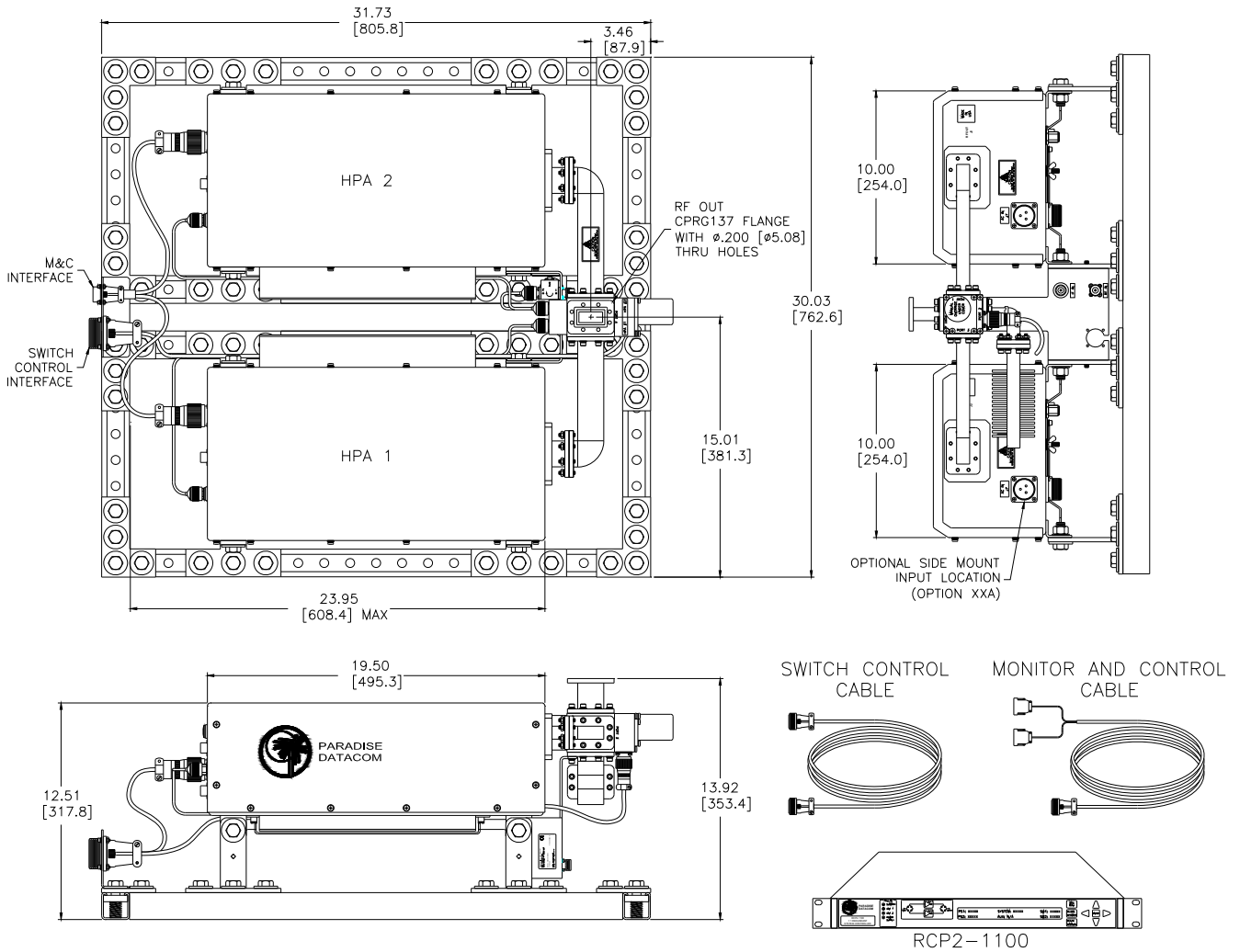

**Outline Drawing, 1:1 C-Band Compact Outdoor SSPA System with RCP2-1100**



### Part Number Configuration Matrix, GaAs High Power Outdoor Systems

HPA **C 2 4 0 0 A H M B S X X**

| Band    |          |
|---------|----------|
| C-Band  | <b>C</b> |
| X-Band  | <b>X</b> |
| Ku-Band | <b>K</b> |

| Generation |          |
|------------|----------|
| Second     | <b>2</b> |

| Power Level (Watts) |                      |
|---------------------|----------------------|
| C-Band              | <b>400, 500, 600</b> |
| X-Band              | <b>350, 500</b>      |
| Ku-Band             | <b>200, 250</b>      |

| Frequency Sub Band   |                    |
|----------------------|--------------------|
| C-Band               |                    |
| <b>A<sup>1</sup></b> | 5.850 to 6.425 GHz |
| <b>B<sup>1</sup></b> | 5.850 to 6.725 GHz |
| <b>C</b>             | 5.750 to 6.670 GHz |
| <b>E<sup>1</sup></b> | 6.425 to 6.725 GHz |
| <b>F<sup>1</sup></b> | 6.725 to 7.025 GHz |
| <b>G</b>             | 5.750 to 6.475 GHz |
| <b>H</b>             | 5.715 to 5.790 GHz |
| <b>J</b>             | 5.740 to 6.650 GHz |
| X-Band               |                    |
| <b>A<sup>1</sup></b> | 7.90 to 8.40 GHz   |
| <b>D</b>             | 7.70 to 8.40 GHz   |
| Ku-Band              |                    |
| <b>A<sup>1</sup></b> | 14.00 to 14.50 GHz |
| <b>B<sup>1</sup></b> | 13.75 to 14.50 GHz |
| <b>F<sup>1</sup></b> | 12.75 to 13.25 GHz |

<sup>1</sup> Available with optional BUC

| Package  |                         |
|----------|-------------------------|
| <b>H</b> | High Power Outdoor SSPA |

| Configuration Modifier 3 |                 |
|--------------------------|-----------------|
| <b>X</b>                 | None (Standard) |

| Configuration Modifier 2 |                            |
|--------------------------|----------------------------|
| <b>X</b>                 | Standard                   |
| <b>R<sup>1</sup></b>     | Receive Band Reject Filter |
| <b>V</b>                 | Reflected Power Monitor    |
| <b>Y<sup>1</sup></b>     | R + V (see above)          |

<sup>1</sup> X-Band units only

| Configuration Modifier 1 |                   |
|--------------------------|-------------------|
| <b>X</b>                 | Standard          |
| <b>S</b>                 | Input Sample Port |

| System Configuration |   |
|----------------------|---|
| <b>A<sup>1</sup></b> | 1:1 System, Input Switching, Internal control       |
| <b>B</b>             | 1:1 System, Input Splitter, Internal control        |
| <b>C<sup>1</sup></b> | 1:2 System, Input Switching, RCP2-1200 <sup>2</sup> |
| <b>F</b>             | 1:1 System, Input Splitter, RCP2-1100 <sup>2</sup>  |
| <b>H<sup>1</sup></b> | 1:1 System, Input Switching, RCP2-1100 <sup>2</sup> |

<sup>1</sup> Input switching with an external reference BUC requires a reference distribution box.

<sup>2</sup> Standard cable length of 100 ft. (30m) with RCP unit.

| Block Up Converter |                        |
|--------------------|------------------------|
| <b>M</b>           | Internal Reference BUC |
| <b>P</b>           | External Reference BUC |
| <b>X</b>           | No BUC                 |

**Example** - A 1:1 Redundant System with Input Splitting and Internal Redundancy Control, using two (2) 400W GaAs C-Band High Power Outdoor SSPAs with optional input sample ports and optional internal reference block up converters is part number: **HPAC2400AHMBSXX**.

### Part Number Configuration Matrix, GaN High Power Outdoor Systems

HPA **C 2 8 0 0 A H M B X X X G**

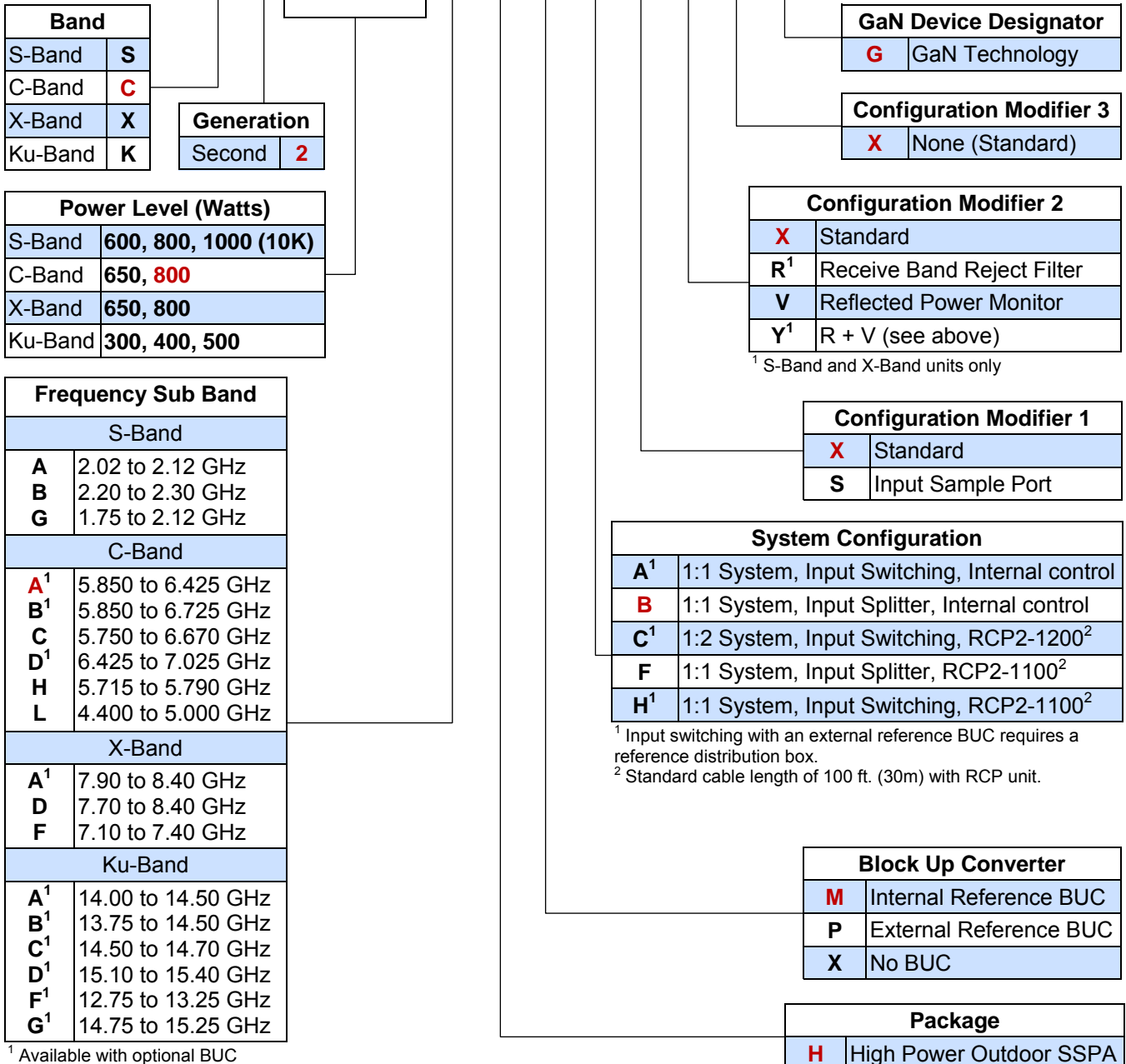

<sup>1</sup> Available with optional BUC

**Example** — A 800W GaN C-Band (5.85 to 6.425 GHz) 1:1 Redundant High Power Outdoor SSPA System with input splitting, an internal reference block up converter and internal redundancy control is model number: **HPAC2800AHMBXXXG**.

### Part Number Configuration Matrix, GaAs Compact Outdoor Systems

HPA **K 2 0 7 0 A C M B X X X**

| Band    |          |
|---------|----------|
| C-Band  | <b>C</b> |
| X-Band  | <b>X</b> |
| Ku-Band | <b>K</b> |

| Generation |          |
|------------|----------|
| Second     | <b>2</b> |

| Power Level (Watts) |  |
|---------------------|--|
| C-Band              | <b>030, 040, 050, 075, 100, 140, 200, 250, 300</b> |
| X-Band              | <b>025, 030, 060, 075, 100, 140, 200, 250</b>      |
| Ku-Band             | <b>010, 020, 025, 035, 040, 050, 070, 100, 125</b> |

| Frequency Sub Band      |                    |
|-------------------------|--------------------|
| C-Band                  |                    |
| <b>A</b> <sup>1</sup>   | 5.850 to 6.425 GHz |
| <b>B</b> <sup>1</sup>   | 5.850 to 6.725 GHz |
| <b>C</b>                | 5.750 to 6.670 GHz |
| <b>E</b> <sup>1</sup>   | 6.425 to 6.725 GHz |
| <b>F</b> <sup>1</sup>   | 6.725 to 7.025 GHz |
| <b>G</b>                | 5.750 to 6.475 GHz |
| <b>H</b>                | 5.715 to 5.790 GHz |
| <b>J</b>                | 5.740 to 6.650 GHz |
| <b>V</b> <sup>1,2</sup> | 5.850 to 6.725 GHz |
| X-Band                  |                    |
| <b>A</b> <sup>1</sup>   | 7.90 to 8.40 GHz   |
| <b>B</b>                | 7.50 to 8.50 GHz   |
| <b>D</b>                | 7.70 to 8.40 GHz   |
| Ku-Band                 |                    |
| <b>A</b> <sup>1</sup>   | 14.00 to 14.50 GHz |
| <b>B</b> <sup>1</sup>   | 13.75 to 14.50 GHz |

<sup>1</sup> Available with optional BUC  
<sup>2</sup> With 1.3:1 VSWR

| Package  |                      |
|----------|----------------------|
| <b>C</b> | Compact Outdoor SSPA |

| Configuration Modifier 3 |                                       |
|--------------------------|---------------------------------------|
| <b>X</b>                 | None (Standard)                       |
| <b>A</b>                 | Side-mount AC Input, Location 'A'     |
| <b>D</b>                 | 48 VDC Input                          |
| <b>F</b>                 | Side-mount 48 VDC Input, Location 'A' |

| Configuration Modifier 2 |                            |
|--------------------------|----------------------------|
| <b>X</b>                 | Standard                   |
| <b>M</b>                 | MS-Connector Covers        |
| <b>R</b> <sup>1</sup>    | Receive Band Reject Filter |
| <b>S</b>                 | M + R (see above)          |

<sup>1</sup> X-Band units only

| Configuration Modifier 1 |               |
|--------------------------|---------------|
| <b>X</b>                 | Standard      |
| <b>K</b>                 | 110 VAC Input |

<sup>1</sup> Available in C- and X-Band models ≥ 140W and Ku-Band models ≥ 100W

| System Configuration  |   |
|-----------------------|---|
| <b>A</b> <sup>1</sup> | 1:1 System, Input Switching, Internal control       |
| <b>B</b>              | 1:1 System, Input Splitter, Internal control        |
| <b>C</b> <sup>1</sup> | 1:2 System, Input Switching, RCP2-1200 <sup>2</sup> |
| <b>F</b>              | 1:1 System, Input Splitter, RCP2-1100 <sup>2</sup>  |
| <b>H</b> <sup>1</sup> | 1:1 System, Input Switching, RCP2-1100 <sup>2</sup> |

<sup>1</sup> Input switching with an external reference BUC requires a reference distribution box.

<sup>2</sup> Standard cable length of 100 ft. (30m) with RCP unit.

| Block Up Converter |                        |
|--------------------|------------------------|
| <b>M</b>           | Internal Reference BUC |
| <b>P</b>           | External Reference BUC |
| <b>X</b>           | No BUC                 |

**Example** — A 70W GaAs Ku-Band (14.0 to 14.5 GHz) 1:1 Redundant Compact Outdoor SSPA System with input splitting, an internal reference block up converter, and internal redundancy control is model number: **HPAK2070ACMBXXX**.

### Part Number Configuration Matrix, GaN Compact Outdoor Systems

HPA **X 2 3 0 0 A C M C X X X G**

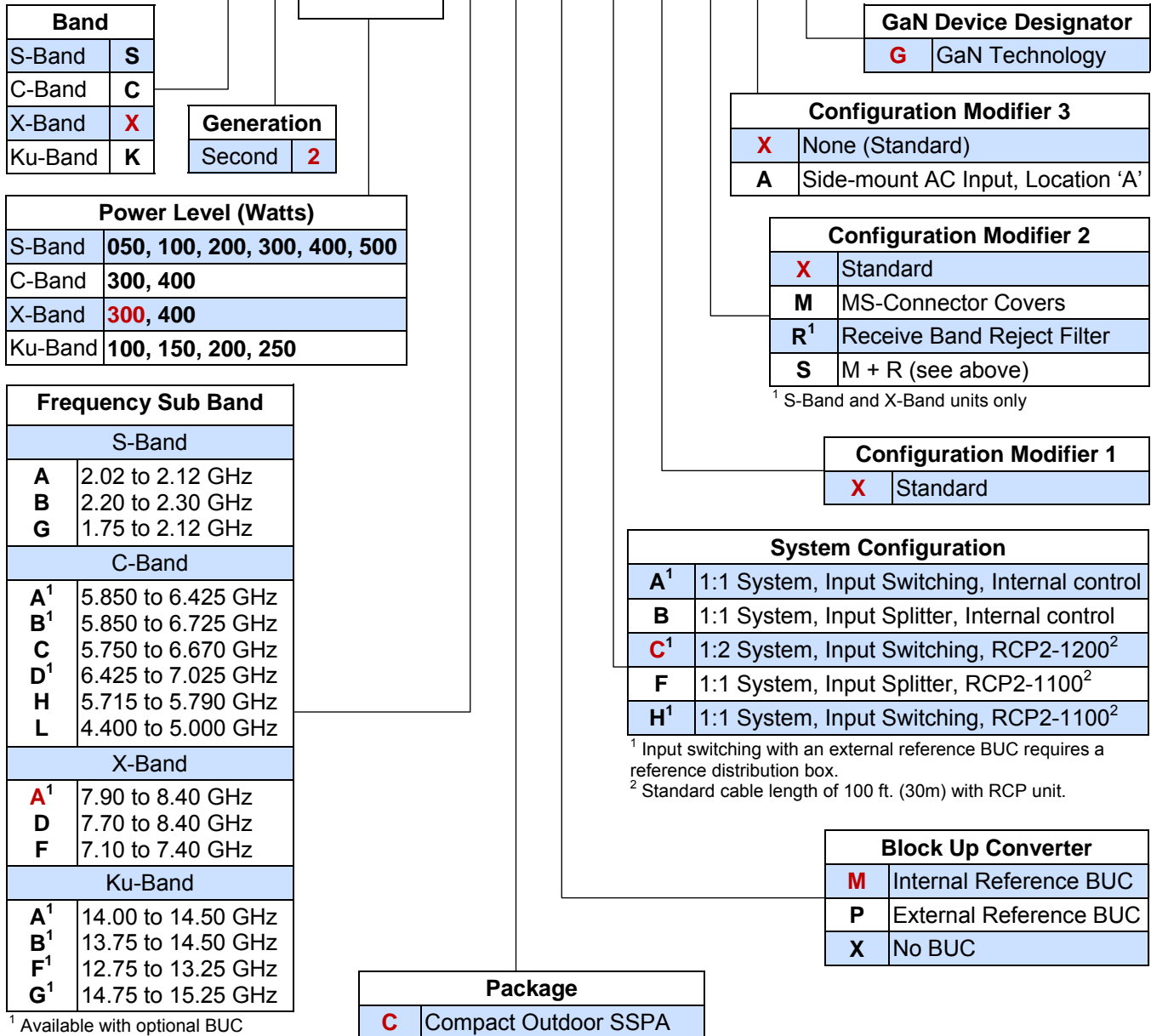

<sup>1</sup> Available with optional BUC

**Example** — A 300W GaN X-Band (7.9 to 8.4 GHz) 1:2 Redundant Compact Outdoor SSPA System with input switching, an internal reference block up converter, and redundancy control with a RCP2-1200 controller is model number: **HPAX2300ACMCXXG**.

#### Use and Disclosure of Data

The information contained herein is classified as EAR99 under the U.S. Export Administration Regulations. Export, re-export or diversion contrary to U.S. law is prohibited.

Specifications are subject to change without notice.