



7RU SSPA Chassis

## DESCRIPTION

Teledyne Paradise Datacom's 7RU Indoor, High Power Rack Mount series of SSPAs represent the industry's highest power density and most reliable high power amplifier systems.

The High Power Rack Mount SSPA employs a modular design, which allows quick and easy replacement in the event of a catastrophic failure of one of the SSPA components. These modular assemblies include: hot-swap SSPA modules, front and rear fan trays; and a rear panel controller card. These amplifiers are powered via a separate power supply chassis.

The power supply is configured as a n+1 redundant, hot swappable, power supply comprised of up to four modules. The power supply is configured such that one module is redundant. In the event of a single power supply module failure, the HPA system will not fail. The power supply module can then be changed without ever taking the HPA out of service.

## FEATURES

- Extremely High Power Density:  
to 1.1 kW C-Band;  
to 1000W X-Band;  
to 500W Ku-Band.
- Hot Swap, n+1 Redundant Power Supply
- Power Factor Corrected Power Supply
- Modular (soft-fail) Architecture
- Removable fan assemblies
- Ethernet Port
- RF Output Sample Port
- Built-in 1:1 Redundancy Control
- Built-in Maintenance Switch Controller

## OPTIONS

- Extended Frequency Band
- L-Band Input
- Reflected Power Monitor
- Phase Combined Systems
- Remote Control Panel
- RF Input Sample Port
- Rear Panel Air Intake and Exhaust

## SPECIFICATIONS

- SSPA Chassis housing:  
7 Rack Units (RU)  
19.0 X 12.22 X 30.0 in  
483 X 310 X 762 mm  
180 lbs / 82 kg
- 1RU Power Supply:  
19.0 X 1.75 X 16.1 in  
483 X 44 X 409 mm  
29 lbs / 13 kg
- Gray powder coat finish
- Operating temperature:  
0 to +50 °C

Request A Quote

## Power Specifications

BAND	PARAMETER	NOTES	LIMITS	UNITS
C-BAND	Frequency Range	(see options for extended band)	5.850 to 6.425	GHz
	Output Power @: Saturation/P <sub>1dB</sub> (Typical/Guaranteed minimum)	HPAC7800ARXXXXX HPAC7900ARXXXXX HPAC711KARXXXXX	P <sub>sat</sub> / P <sub>1dB</sub> 59.0 (800) / 58.0 (630) 59.5 (900) / 58.5 (700) 60.4 (1100) / 60.0 (1000)	dBm (W) dBm (W) dBm (W)
	Power Requirements Line Frequency Power Factor Line Power (Voltage) (typical @ 220 VAC)	HPAC7800ARXXXXX HPAC7900ARXXXXX HPAC711KARXXXXX	47 to 63 .90 4150 (180 to 265) 4850 (180 to 265) 6000 (180 to 265)	Hz W (VAC) W (VAC) W (VAC)
X-BAND	Frequency Range		7.9 to 8.4	GHz
	Output Power @: Saturation/P <sub>1dB</sub> (Typical/Guaranteed minimum)	HPAX7700ARXXXXX HPAX710KARXXXXX	P <sub>sat</sub> / P <sub>1dB</sub> 58.5 (700) / 58.1 (650) 60.0 (1000) / 59.5 (900)	dBm (W) dBm (W)
	Power Requirements Line Frequency Power Factor Line Power (Voltage) (typical @ 220 VAC)	HPAX7700ARXXXXX HPAX710KARXXXXX	47 to 63 .90 5500 (180 to 265) 6000 (180 to 265)	Hz W (VAC) W (VAC)
KU-BAND	Frequency Range	(see options for extended band)	14.0 to 14.5	GHz
	Output Power @: Saturation/P <sub>1dB</sub> (Typical/Guaranteed minimum)	HPAK7250ARXXXXX HPAK7400ARXXXXX HPAK7500ARXXXXX	P <sub>sat</sub> / P <sub>1dB</sub> 54.0 (250) / 53.0 (200) 56.0 (400) / 55.0 (300) 57.0 (500) / 56.0 (400)	dBm (W) dBm (W) dBm (W)
	Power Requirements Line Frequency Power Factor Line Power (Voltage) (typical @ 220 VAC)	Power Factor Corrected HPAK7250ARXXXXX HPAK7400ARXXXXX HPAK7500ARXXXXX	47 to 63 .90 2200 (180 to 265) 4600 (180 to 265) 5100 (180 to 265)	Hz W (VAC) W (VAC) W (VAC)

## Options

Extended C-Band 5.850 to 6.725 GHz 5.750 to 6.670 GHz	De-rate power by 1.0 dB linearly from 6.425 to 6.725 GHz De-rate power by 1.0 dB linearly from 6.425 to 6.670 GHz and by 0.5 dB from 5.750 to 5.850	HPAC7XXXBRXXXXX HPAC7XXXCRXXXXX
Extended Ku-Band 13.75 to 14.5 GHz	De-rate power by 1.0 dB linearly from 13.75 to 14.0 GHz	HPAK7XXXBRXXXXX
Reflected Power Monitor		See Configuration Matrix
RF Input Sample Port (-10 dB)		See Configuration Matrix

## General Specifications: 7RU RM Series

PARAMETER	NOTES	LIMITS	UNITS
Gain	minimum	75	dB
Gain Flatness	full band	± 1.0	dB
	Extended C-Band units	± 1.5	dB
Gain Slope	per 40 MHz	± 0.3	dB/40 MHz
Gain Variation vs. Temperature	0 °C to +50 °C	± 1.0	dB
Gain Stability	at constant temperature	± 0.25	dB/24 hours
Gain Adjustment	0.1 dB resolution	20	dB
Intermodulation Distortion	3 dB back off relative to P <sub>1dB</sub>	-25	dBc
AM/PM Conversion	(@ rated P <sub>1dB</sub> )	3.5	°/dB
	(@ P <sub>1dB</sub> - 3 dB)	0.5	°/dB
Spurious	(@ rated P <sub>1dB</sub> )	-65	dBc
Harmonics	(@ rated P <sub>1dB</sub> - 3 dB)	-50	dBc
Input/Output VSWR	All units except Extended C-Band Extended C-Band units <sup>1</sup>	1.30:1 1.50:1	
Noise Figure	at maximum gain	12	dB
Group Delay (per 40 MHz segment)	Linear	0.01	ns/MHz
	Parabolic	0.003	ns/MHz <sup>2</sup>
	Ripple	1.0	ns p-p
Noise Output	TX Band	-75	dBW/4 KHz
	RX Band (C- or Ku-Band)	-150	dBW/4 KHz
	RX Band (X-Band)	-100	dBW/4 KHz
Residual AM Noise	0 - 10 KHz	-45	dBc
	10 KHz - 500 KHz	-20 (1.25 + log F)	dBc
	500 KHz - 1 MHz	-80	dBc
Phase Noise		IESS -308/309 - 10 dB	

## Mechanical

Size		19.0 X 10.47 X 30.0	inches
HPA Chassis	width X height X depth	483 X 266 X 762	mm
Power Supply Chassis	width X height X depth	19.0 X 1.75 X 16.1	inches
		483 X 44 X 409	mm
Weight			
HPA Chassis		180 (82)	lbs.(kg)
Power Supply Chassis (1RU)		29 (13)	lbs.(kg)
Finish		powder coat	Gray

## Environmental

Operating Temperature	Ambient	0 to +50	°C
Storage Temperature	Ambient	-20 to +75	°C
Operating Relative Humidity	Non-condensing	95	%
Storage Relative Humidity	Non-condensing	90	%
Cooling System	Integrated	Forced air	
Operational Altitude	From sea level	+10,000 (+3,048)	ft. (m)

<sup>1</sup> Extended C-Band units may meet 1.30:1 as a special option. Discuss with your sales representative.

## Interface Specifications; 7RU RM Series

PORT	NOTES	LIMITS	PIN-OUT
Monitor & Control (J7)	Parallel Port Outputs	Power Supply Fault Auxiliary Fault Mute BUC Fault Temperature Fault Voltage Fault DC Current Fault Low RF Fault	Form C relay Form C relay Form C relay Form C relay Form C relay Form C relay Form C relay Form C relay
Monitor & Control (J7)	Parallel Port Inputs	Mute Input Local / Remote Fault Clear Standby Select Auxiliary Fault Ground	Opto Isolator Opto Isolator Opto Isolator Opto Isolator Opto Isolator
Main Serial Port (J4)	RS232 / RS485 DB9 (F)	RS232 Out, RS485 TX- RS232 In, RS485 RX- RS485 RX+ RS485 TX+ Service Request 1 Service Request 2 Service Request Common Termination Ground	Pin 2 Pin 3 Pin 4 Pin 1 Pin 6 Pin 8 Pin 7 Pin 9 Pin 5
Auxiliary Serial Port (J5)	RS232 / RS485 DB9 (F)	RS232 In, RS485 RX- RS232 Out, RS485 TX- RS232 DTR, RS485 TX+ RS485 RX+ Termination Ground	Pin 2 Pin 3 Pin 4 Pin 1 Pin 9 Pin 5
Link Port (J8)	1:1 Redundant System Control Link DB9 (F)	RS485+ RS485- Link Out Link In Ground	Pin 1,4 Pin 2,3 Pin 6,7 Pin 8,9 Pin 5
Switch Port (J3)	Redundant Switch Control Molex (43810-0002)	+28 VDC RF Switch 1, pos 1 RF Switch 1, pos 2 RF Switch 2, pos 1 RF Switch 2, pos 2	Pin 1,4 Pin 3 Pin 2 Pin 6 Pin 5
Program Port (J6)	Flash Firmware Program Port	DB25(F)	-
Ethernet Port (J9)	RJ45	TX+ TX- RX- RX+ Ground	Pin 1 Pin 2 Pin 3 Pin 6 Pins 4,5,7,8
Connectors	RF Input, Input & Output Sample RF Output HPAK7XXXR HPAC7XXXR HPAX7XXXR Line Power	Type N  WR75 Waveguide WR137 Waveguide WR112 Waveguide (3) IEC feeds	Female  Grooved (PBR-120) CPR137G flange CPR112G (PDR-84) Plug

## Power Supply Options

At all power levels, the 7RU Chassis is fitted with the standard 1RU, four-module power supply configuration.



## Hot-Swap SSPA Modules

Four SSPA modules are phase combined inside the 7RU Rack Mountable SSPA to produce the amplifiers total output power. Each of the SSPA modules is hot-swappable, allowing the unit to remain in service while a failed SSPA module is replaced.

The chassis front panel is removable to access the SSPA modules, even while the unit is in operation.

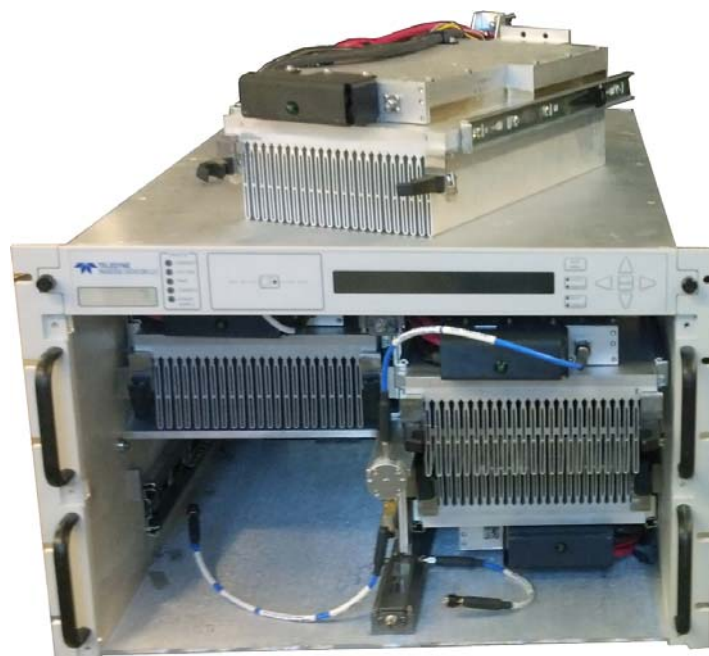

## L-Band Operation

Teledyne Paradise Datacom amplifiers are available with an integrated L-Band Block Up Converter. L-Band units utilize Teledyne Paradise Datacom's proprietary zBUC technology. The addition of a zBUC<sup>®</sup> converter to the SSPA typically increases the gain by 2-4 dB. The advantages of zBUC technology include:

- zBUC converter can detect and switch to an externally supplied reference.
- Optional internal high stability (10MHz) reference.
- zBUC converter can lock to an externally supplied reference of 10 or 50 MHz.
- zBUC converter can accept a wide range of external reference power (-10 to +5 dBm).

## Available Frequency Plans

Band	Frequency Band	IF Input	LO Frequency	RF Output	Gain Change
C	Standard C-Band	950 - 1525 MHz	4.900 GHz	5.850 - 6.425 GHz	0-4 dB
C	Extended C-Band	950 - 1825 MHz	4.900 GHz	5.850 - 6.725 GHz	0-4 dB
C	Palapa Band	950 - 1250 MHz	5.475 GHz	6.425 - 6.725 GHz	0-4 dB
C	Insat Band	950 - 1250 MHz	5.775 GHz	6.725 - 7.025 GHz	0-4 dB
C	Extended C-Band 2	950 - 1675 MHz	4.800 GHz	5.750 - 6.475 GHz	0-4 dB
C	Low C-Band	840 - 1000 MHz	4.250 GHz	5.090 - 5.250 GHz	0-4 dB
X	Standard X-Band	950 - 1450 MHz	6.950 GHz	7.900 - 8.400 GHz	0-2 dB
Ku	Standard Ku-Band	950 - 1450 MHz	13.050 GHz	14.00 - 14.50 GHz	0-2 dB
Ku	Extended Ku-Band	950 - 1700 MHz	12.800 GHz	13.75 - 14.50 GHz	0-2 dB

## Electrical Specifications for 7RU RM SSPA with ZBUC converter

PARAMETER	NOTES	LIMITS				UNITS
Gain	Nominal setting	75				dB
Gain Flatness	full band (C-,X-,Ku-bands)	± 2.0				dB
Gain Slope	per 40 MHz (C-,X-,Ku-bands)	± 0.5				dB/40 MHz
Gain Adjusted Range		20				dB
	Typical C-Band Adj. Range	60 - 80				dB
	Typical Ku-Band Adj. Range	57 - 77				dB
Gain Stability	-40 to +60 °C	± 1.5				dB
Phase Noise	Offset frequency from carrier	<u>Absolute max.</u>	<u>C-band (typ.)</u>	<u>X-band (typ.)</u>	<u>Ku-band (typ.)</u>	
	10 Hz	-30	-60	-60	-50	dBc/Hz
	100 Hz	-60	-80	-75	-65	dBc/Hz
	1 KHz	-70	-80	-75	-72	dBc/Hz
	10 KHz	-80	-85	-100	-90	dBc/Hz
	100 KHz	-90	-120	-110	-110	dBc/Hz
	1 MHz	-90	-125	-122	-120	dBc/Hz
Spurious	In-Band Signal Related (C-/Ku-Band) (Extended C-Band)					-50 dBc
	Close to Carrier Spurious (≤ 20 MHz) Local Oscillator					-50 -30 dBc dBm
Noise Figure	At 75 dB gain setting	20				dB
Input VSWR	L-Band	1.5 : 1				
Internal Reference Option	Reference Accuracy (initial)	± 1 • 10 <sup>-8</sup>				
	Aging per day (after 30 days)	± 1 • 10 <sup>-9</sup>				
	Aging per year (after 30 days)	± 6 • 10 <sup>-8</sup>				
	Reference Stability over Temperature (-40 to +40 °C, ambient)	± 1 • 10 <sup>-8</sup>				

## Part Number Configuration Matrix

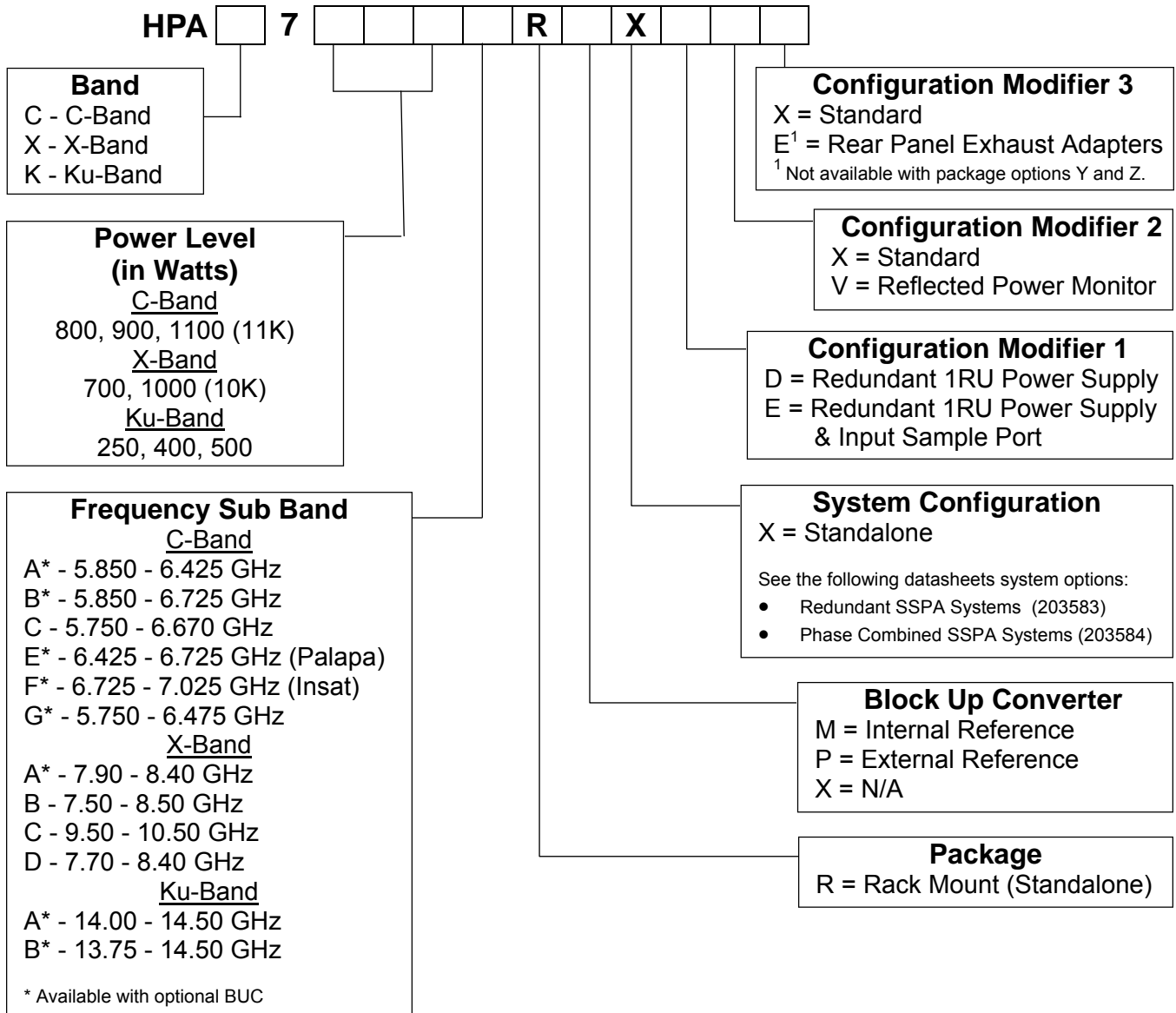

**Example** - A standalone 800W C-Band high power rack mount SSPA operating at 5.85 to 6.425 GHz, with a 1RU redundant power supply and optional input sample port is part number: **HPAC7800ARXXEXX**.

### Use and Disclosure of Data

The information contained herein is classified as EAR99 under the U.S. Export Administration Regulations. Export, re-export or diversion contrary to U.S. law is prohibited.

Specifications listed in this document are subject to change without notice.