



650W X-Band 5RU SSPA Chassis

Teledyne Paradise Datacom's Indoor, Rack Mount (R) series SSPAs represent the latest in High Power Microwave Amplifier Technology. The 5RU SSPA chassis achieves the highest power density in the industry along with enhanced maintainability.

Local control is available with a user-friendly front panel interface. Five fault condition LEDs reflect some of the SSPA major faults states, plus a summary fault indicator. The SSPA online LED turns green when the amplifier is in Online mode (1:1 Mode) or serves as an AC power indicator in standalone mode. Local/Remote and Mute/Unmute LEDs show the current control mode and mute state of the amplifier.

Serial and parallel (contact closure) control is also available from the rear panel. Our free Universal M&C software allows monitor and control of the SSPA from a remote computer.

A state of the art thermal platform provides efficient cooling for the amplifier module and power supplies. This ensures the highest possible MTBFs for microwave power amplifiers.

Prime power to the amplifier is provided by a separate, external power supply in an N+1 redundant configuration. A failure of one power supply module will not take the amplifier off the air.

FEATURES

- Extremely High Power Density:
 - to 1.6 kW X-Band
 - to 1.6 kW C-Band
 - to 1.0 kW Ku-Band
- Removable Fan Tray and Monitor & Control Card Assembly
- Remote Communication via RS232/485 or Ethernet
- RF Output Sample Port
- 20 dB Gain Adjustment
- 1RU N+1 Power Supply
- True RF Output Power Measurement
- Built-in Maintenance Switch Controller

OPTIONS

- Remote Control Panel
- L-Band Input operation
- Reflected Power Monitor
- Input Sample Port
- Exhaust Duct Adapters
- Redundant Systems
- Phase Combined Systems

[Request A Quote](#)

Specifications, C-Band SSPAs

PARAMETER	NOTES	LIMITS	UNITS
Frequency Range	Frequency selection "G" Frequency selection "A" Frequency selection "B" ¹ Frequency selection "D"	5.750 to 6.475 5.850 to 6.425 5.850 to 6.725 6.425 to 7.025	GHz GHz GHz GHz
Output Power Typical, P _{sat} Guaranteed minimum, P _{1dB}	HPAC5400ARXXXXP HPAC5500ARXXXXP HPAC5600ARXXXXP HPAC5800ARXXXXP HPAC510KARXXXXP HPAC513KARXXXXP	P _{sat} / P _{1dB} 56.0 (400) / 55.0 (316) 57.0 (500) / 56.0 (400) 57.8 (600) / 57.0 (500) 59.0 (800) / 57.7 (590) 60.0 (1000) / 58.7 (750) 61.0 (1250) / 59.7 (933)	dBm (W) dBm (W) dBm (W) dBm (W) dBm (W) dBm (W)
Power Requirements Line Frequency Line Power (Voltage) (typical @ 220 VAC)	power factor HPAC5400ARXXXXP HPAC5500ARXXXXP HPAC5600ARXXXXP HPAC5800ARXXXXP HPAC510KARXXXXP HPAC513KARXXXXP	.98 47 to 63 2400 (180 to 265) 2800 (180 to 265) 3700 (180 to 265) 4600 (180 to 265) 5500 (180 to 265) 7000 (180 to 265)	Hz W (VAC) W (VAC) W (VAC) W (VAC) W (VAC) W (VAC)

Note 1: De-rate output power by 1 dB linearly from 6.425 to 6.725 GHz.

Specifications, X-Band SSPAs

PARAMETER	NOTES	LIMITS	UNITS
Frequency Range	Frequency selection "D" ¹ Frequency selection "A"	7.70 to 8.40 7.90 to 8.40	GHz GHz
Output Power Typical, P _{sat} Guaranteed minimum, P _{1dB}	HPAX5250ARXXXXP HPAX5350ARXXXXP HPAX5500ARXXXXP HPAX5700ARXXXXP HPAX510KARXXXXP	P _{sat} / P _{1dB} 54.0 (250) / 53.3 (214) 55.5 (354) / 54.5 (282) 57.0 (500) / 56.0 (400) 58.5 (700) / 57.2 (525) 60.0 (1000) / 58.7 (740)	dBm (W) dBm (W) dBm (W) dBm (W) dBm (W)
Power Requirements Line Frequency Line Power (Voltage) (typical @ 220 VAC)	power factor HPAX5250ARXXXXP HPAX5350ARXXXXP HPAX5500ARXXXXP HPAX5700ARXXXXP HPAX510KARXXXXP	.98 47 to 63 2450 (180 to 265) 3000 (180 to 265) 3500 (180 to 265) 6000 (180 to 265) 7000 (180 to 265)	Hz W (VAC) W (VAC) W (VAC) W (VAC) W (VAC)

Note 1: De-rate output power by 1 dB linearly from 7.90 to 7.70 GHz.

Specifications, Ku-Band SSPAs

PARAMETER	NOTES	LIMITS	UNITS
Frequency Range	Frequency selection "F" ¹ Frequency selection "B" Frequency selection "A"	12.75 to 13.25 13.75 to 14.50 14.00 to 14.50	GHz GHz GHz
Output Power Typical, P _{sat} Guaranteed minimum, P _{1dB}	HAK5200ARXXXXP HAK5250ARXXXXP HAK5400ARXXXXP HAK5500ARXXXXP	P _{sat} / P _{1dB} 53.0 (200) / 51.7 (150) 54.0 (250) / 52.7 (190) 56.0 (400) / 54.7 (300) 57.0 (500) / 55.7 (372)	dBm (W) dBm (W) dBm (W) dBm (W)
Power Requirements Line Frequency Line Power (Voltage) (typical @ 220 VAC)	power factor HAK5200ARXXXXP HAK5250ARXXXXP HAK5400ARXXXXP HAK5500ARXXXXP	.98 47 to 63 2200 (180 to 265) 2400 (180 to 265) 5000 (180 to 265) 5600 (180 to 265)	Hz W (VAC) W (VAC) W (VAC) W (VAC)

Note 1: De-rate output power by 1 dB linearly from 14.00 to 13.75 GHz.

Common Electrical Specifications

PARAMETER	NOTES	LIMITS	UNITS
Gain	range	55-75	dB
Gain Flatness	full band	± 1.0	dB
	full band (Extended C-Band)	± 1.5	dB
Gain Slope	per 40 MHz	± 0.3	dB/40 MHz
Gain Variation vs. Temperature	0 °C to +50 °C	± 1.0	dB
Gain Stability	at constant temperature	± 0.25	dB / 24 hours
Gain Adjustment	0.1 dB resolution	20	dB
Intermodulation Distortion (Two-tone, 5 MHz spacing)	At P _{1dB} (P _{sat} - 3 dB)	-25	dBc
AM/PM Conversion	@ rated P _{1dB}	≤ 1.0	°/dB
Spurious	@ rated P _{1dB}	-65	dBc
Harmonics (SSPA only)	@ rated P _{1dB}	-50	dBc
Input/Output VSWR	Extended C-Band	1.30:1	
	Output VSWR: Ku-Band with bulkhead filter	1.50:1	
		1.40:1	
Noise Figure	at maximum gain	10	dB
Group Delay (per 40 MHz segment)	Linear	0.01	ns/MHz
	Parabolic	0.003	ns/MHz ²
	Ripple	1.0	ns p-p
Transmit Band Noise Output Power Density	TX Band	-75	dBW/4 KHz
Residual AM Noise, typical	Offset frequency from carrier		
	1 Hz	-110	dBc/Hz
	10 Hz	-120	dBc/Hz
	100 Hz	-130	dBc/Hz
	1 KHz	-135	dBc/Hz
	10 KHz	-140	dBc/Hz
	100 KHz	-140	dBc/Hz
	1 MHz	-140	dBc/Hz
Residual Phase Noise, typical (SSPA only)	Offset frequency from carrier		
	10 Hz	-90	dBc/Hz
	100 Hz	-100	dBc/Hz
	1 KHz	-110	dBc/Hz
	10 KHz	-120	dBc/Hz
	100 KHz	-125	dBc/Hz
	1 MHz	-130	dBc/Hz
True RF Power Detector	Range	P _{sat} to (P _{sat} - 20)	dB
	Accuracy	± 0.5	dBm

Specifications are subject to change without notice.

1RU N+1 Redundant Power Supply

The combination of a separate, fully redundant power supply is an excellent means of obtaining the ultimate in system reliability. The power supply is an N+1 redundant configuration, meaning that there is one more power supply module available than required to operate the SSPA. A failure of one power supply module will not take the amplifier off the air.



L-Band Operation

Teledyne Paradise Datacom amplifiers are available with an integrated L-Band Block Up Converter. L-Band units utilize Teledyne Paradise Datacom's proprietary zBUC technology. The addition of a zBUC[®] converter to the SSPA typically increases the gain by 2-4 dB. The advantages of zBUC technology include:

- zBUC converter can detect and switch to an externally supplied reference.
- Optional internal high stability (10MHz) reference.
- zBUC converter can lock to an externally supplied reference of 10 or 50 MHz.
- zBUC converter can accept a wide range of external reference power (-10 to +5 dBm).

Available Frequency Plans

Band	Frequency Band	IF Input	LO Frequency	RF Output	Gain Change
C	Standard C-Band	950 - 1525 MHz	4.900 GHz	5.850 - 6.425 GHz	0-4 dB
C	Extended C-Band	950 - 1825 MHz	4.900 GHz	5.850 - 6.725 GHz	0-4 dB
C	Palapa Band	950 - 1250 MHz	5.475 GHz	6.425 - 6.725 GHz	0-4 dB
C	Insat Band	950 - 1250 MHz	5.775 GHz	6.725 - 7.025 GHz	0-4 dB
C	Extended C-Band 2	950 - 1675 MHz	4.800 GHz	5.750 - 6.475 GHz	0-4 dB
C	Low C-Band	840 - 1000 MHz	4.250 GHz	5.090 - 5.250 GHz	0-4 dB
X	Standard X-Band	950 - 1450 MHz	6.950 GHz	7.900 - 8.400 GHz	0-2 dB
Ku	Standard Ku-Band	950 - 1450 MHz	13.050 GHz	14.00 - 14.50 GHz	0-2 dB
Ku	Extended Ku-Band	950 - 1700 MHz	12.800 GHz	13.75 - 14.50 GHz	0-2 dB

Electrical Specifications for 5RU RM SSPA with ZBUC converter

PARAMETER	NOTES	LIMITS				UNITS
Gain	Nominal setting	75				dB
Gain Flatness	full band (C-,X-,Ku-bands)	± 2.0				dB
Gain Slope	per 40 MHz (C-,X-,Ku-bands)	± 0.5				dB/40 MHz
Gain Adjusted Range		20				dB
	Typical C-Band Adj. Range	60 - 80				dB
	Typical Ku-Band Adj. Range	57 - 77				dB
Gain Stability	-40 to +60 °C	± 1.5				dB
Phase Noise	Offset frequency from carrier	<u>Absolute max.</u>	<u>C-band (typ.)</u>	<u>X-band (typ.)</u>	<u>Ku-band (typ.)</u>	
	10 Hz	-30	-60	-60	-50	dBc/Hz
	100 Hz	-60	-80	-75	-65	dBc/Hz
	1 KHz	-70	-80	-75	-72	dBc/Hz
	10 KHz	-80	-85	-100	-90	dBc/Hz
	100 KHz	-90	-120	-110	-110	dBc/Hz
	1 MHz	-90	-125	-122	-120	dBc/Hz
Spurious	In-Band Signal Related (C-/Ku-Band) (Extended C-Band)	-50				dBc
	Close to Carrier Spurious (≤ 20 MHz)	-40				dBc
	Local Oscillator	-50				dBc
		-30				dBm
Noise Figure	At 75 dB gain setting	20				dB
Input VSWR	L-Band	1.5 : 1				
Internal Reference Option	Reference Accuracy (initial)	± 1 • 10 ⁻⁸				
	Aging per day (after 30 days)	± 1 • 10 ⁻⁹				
	Aging per year (after 30 days)	± 6 • 10 ⁻⁸				
	Reference Stability over Temperature (-40 to +40 °C, ambient)	± 1 • 10 ⁻⁸				

Mechanical Specifications

PARAMETER	NOTES	LIMITS	UNITS
Size (SSPA)	width X height X depth	19.0 x 8.75 x 30.0 483 x 222 x 762	inches mm
Size (Power Supply)	width X height X depth	19.0 x 1.75 x 15.97 483 x 45 x 406	inches mm
Weight (SSPA)	With integrated zBUC converter	120 (54.5) +1.7 (+0.8)	lbs. (kg) lbs. (kg)
Weight (Power Supply)	with four (4) power supply modules	29 (13.2)	lbs. (kg)
Finish		Paint	Gray; powder coat
Connectors	RF Input RF Output (C-Band) RF Output (X-Band) RF Output (Ku-Band) RF Output Sample	Type N WR137 Waveguide WR112 Waveguide WR75 Waveguide Type N	Female CPR137G Flange (PDR-70) CPR112G Flange (PDR-84) Grooved flange (PBR-120) Female

Environmental Specifications

PARAMETER	NOTES	LIMITS	UNITS
Operating Temperature	Ambient	0 to +50	°C
Relative Humidity	Non-condensing	95	%
Cooling System	Forced Convection Air Cooling	Front Panel - Intake Rear Panel - Exhaust	
Audible Noise	Measured 1m from unit, at P _{sat}	61	dBA
Altitude	No temperature de-rating up to 10,000 ft, (3000 m) De-rate maximum temperature by 2 °C per 1,000 ft (300 m) beyond 10,000 ft.		
Shock	50 g p-p, 11 msec pulses		
Vibration	3g rms 30 min. 5-2000 Hz		

X-Band Receive Band Filter Option

X-Band GaAs amplifiers may be ordered with an external receive band reject filter. The filter used for frequency band 7.90 to 8.40 GHz is model L205250-X6-TX.

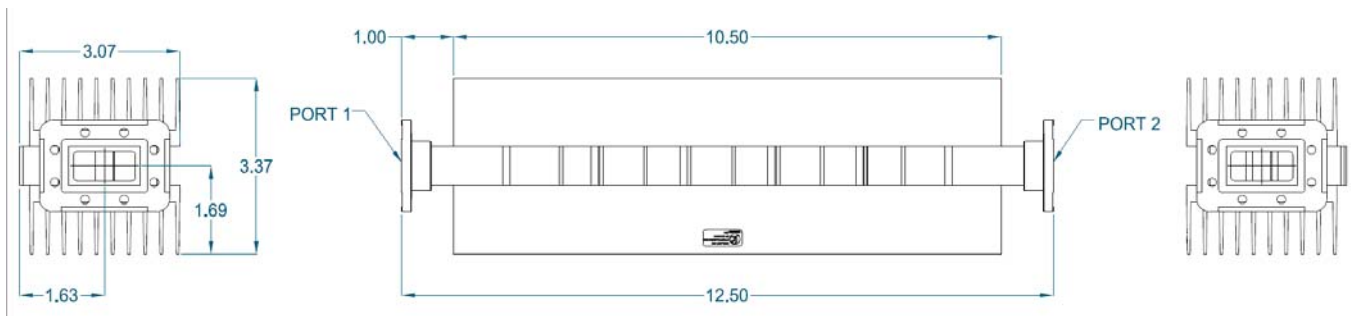

Outline Drawing, Typical C-Band SSPA Chassis

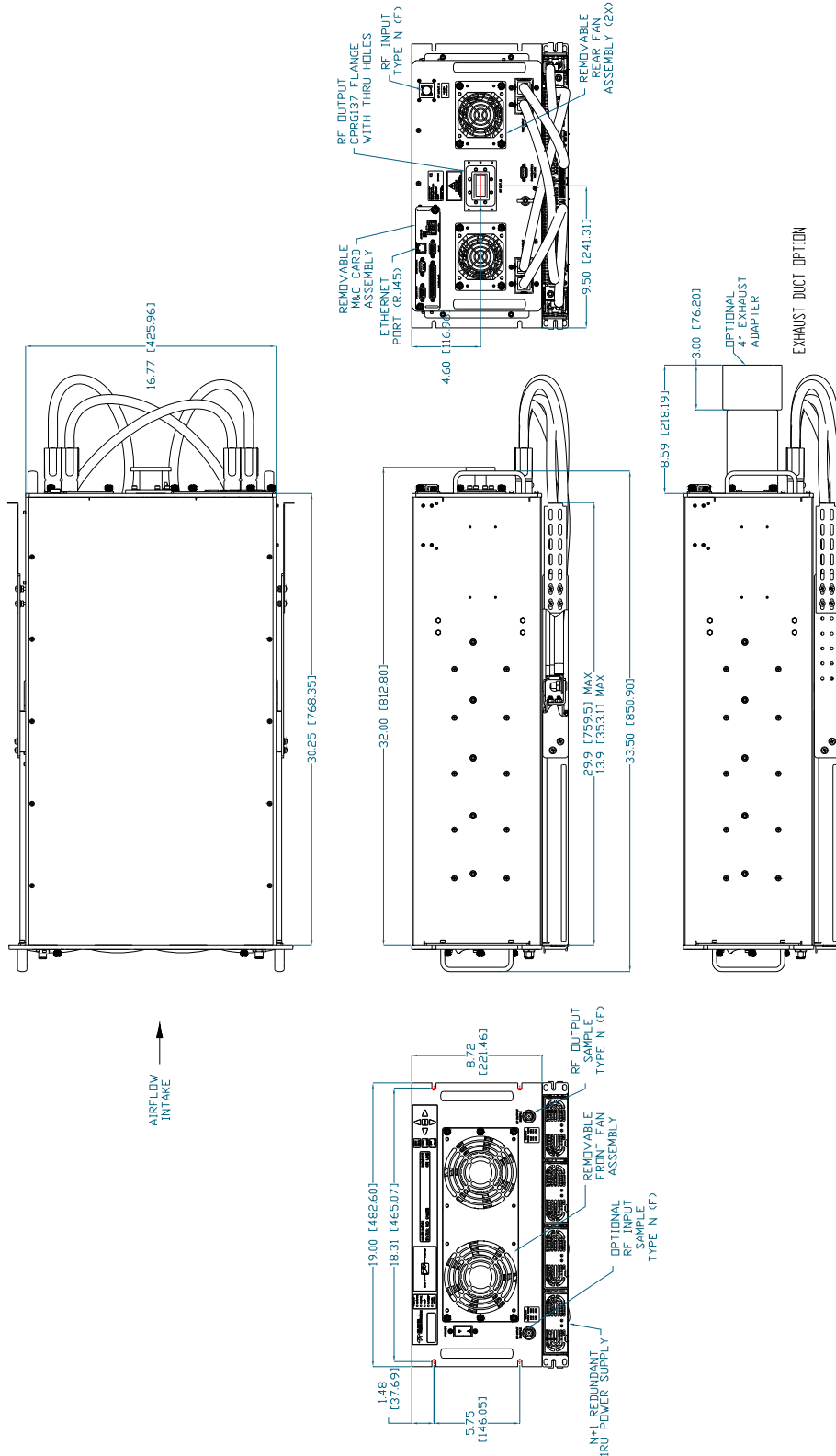

Redundant and Phase Combined Systems

Teledyne Paradise Datacom's 5RU Rack Mount SSPAs can be configured in a variety of redundant and phase combined configurations.

- 1:1 Redundant System with Internal Redundancy Control
- 1:1 Redundant System with RCP2-1100 Redundant System Controller
- 1:1 Fixed Phase Combined System with FPRC-1100 Phase Combined System Controller
- 1:2 Redundant System with Internal Redundancy Control
- 1:2 Redundant System with RCP2-1200 Redundant System Controller
- 1:2 Fixed Phase Combined System with FPRC-1200 Phase Combined System Controller

System Output Power Capacity

Due to residual losses inherent in redundant system configurations (waveguide bends; switch and coupler losses), reduce the typical output power specification of a single amplifier by approximately 0.2 dB for 1:1 and by 0.4 dB for 1:2 systems.

In phase combined systems, these same losses result in slightly less than the ideal addition of 3 dB to the output power of a single HPA unit. For 1:1 phase combined systems, the typical additive output power is approximately 2.70 dB above the output power of a single HPA. For 1:2 phase combined systems, the typical additive output power is approximately 2.50 dB above the output power of a single HPA.

Actual system losses will vary based on the system options.

System Controllers

The RCP2/FPRC-1100/1200 system controller provides an extremely user friendly interface for complete monitor and control of the amplifier system.



RCP2-1100 Redundant System Controller

The front panel mimic display shows the on-line amplifiers and the switch positions. Fault lights are provided for easy identification of system status. All system monitor and control is available locally at the front panel LCD display, as well as remotely by the RS232, RS485, or Ethernet interface ports. Audible alarms and a full compliment of parallel I/O signal are available at the rear panel of the controller.

Indoor Rack Mount GaAs Solid State Power Amplifiers 5RU Rack Height

Part Number Configuration Matrix

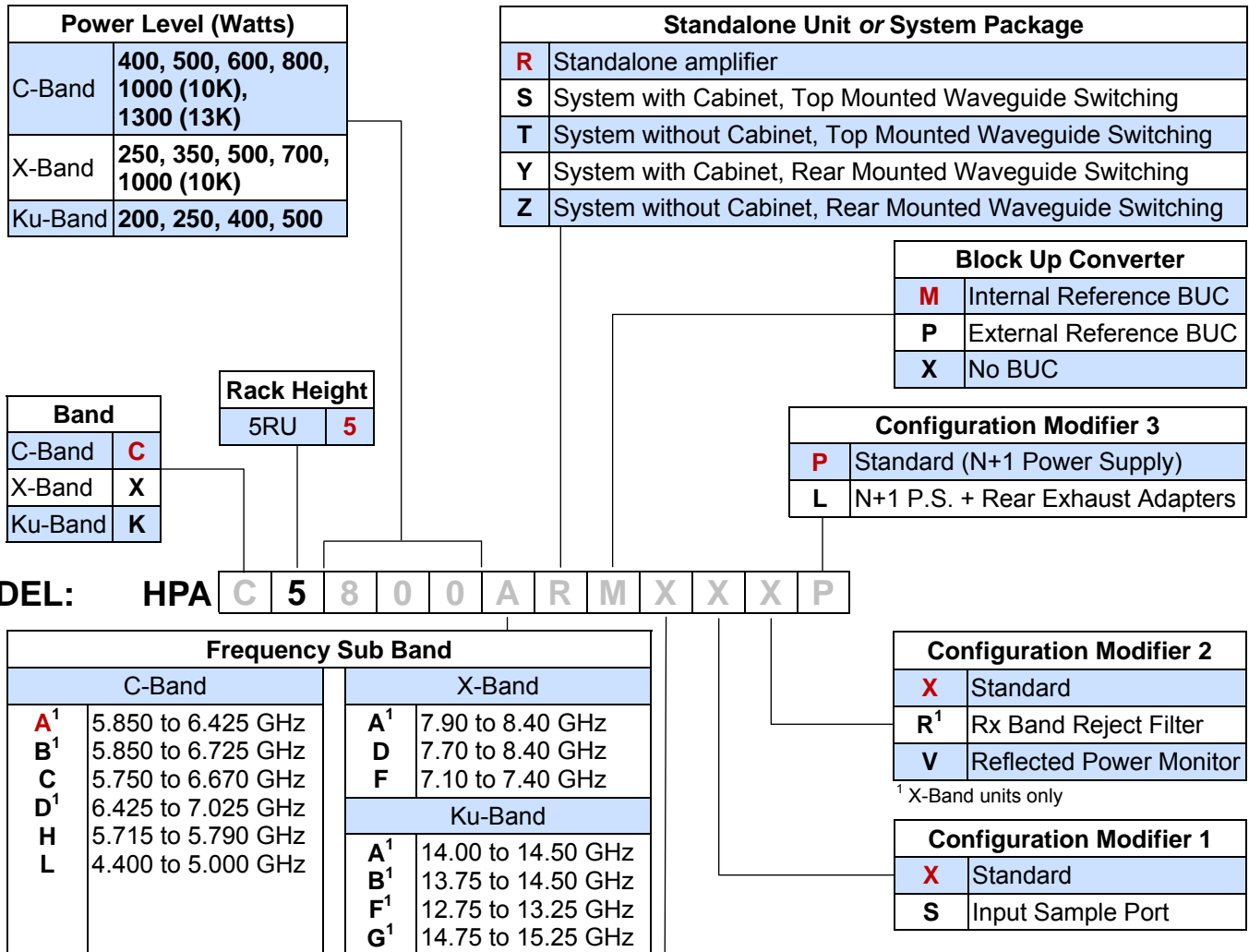

¹ Available with optional BUC

Standalone Unit or System Configuration	
X	Standalone amplifier
A¹	1:1 System, Input Switching, Internal Control
B	1:1 System, Input Splitter, Internal Control
C¹	1:2 System, Input Switching, RCP2-1200 ²
D¹	1:2 System, Input Switching, Internal Control
E	1:2 Phase Combined System, Input Splitter, FPRC-1200 ²
F	1:1 System, Input Splitter, RCP2-1100 ²
G	1:1 Phase Combined system, Input Splitter, FPRC-1100 ²
H¹	1:1 System, Input Switching, RCP2-1100 ²
J	1:2 Phase Combined system, Input splitter, Internal Control

¹ Switched input with external reference BUC requires reference distribution box.
² Standard location for controller is directly above HPA1.

Example - A standalone 800W GaAs C-Band 5RU Rack Mount SSPA with standard N+1 external power supply and an optional internal reference block up converter is part number: **HPAC5800ARMXXXP**.

Use and Disclosure of Data

The information contained herein is classified as EAR99 under the U.S. Export Administration Regulations. Export, re-export or diversion contrary to U.S. law is prohibited.

Specifications are subject to change without notice.