

# Remote Control Panel

## RCP2-1000-RM

### For Rack Mountable SSPAs



**RCP2-1000 Remote Control Panel for Rack Mount SSPAs**

## DESCRIPTION

The Teledyne Paradise Datacom Remote Control Panel (RCP2-1000-RM) was designed to provide easy remote monitor and control of Teledyne Paradise Datacom's Rack Mount Solid State Power Amplifier.

Control of the RCP2-1000-RM can be handled through Front Panel operation, or remotely through Parallel or Serial communication to a remote computer.

The RCP2-1000-RM front panel includes ten LEDs that indicate the internal state of the Rack Mount SSPA. Five fault condition LEDs on the left side of the front panel indicate any SSPA major faults, in addition to a summary fault state.

A 2 line by 40 character LCD provides an extremely user friendly interface. Virtually all of the controller's setup and adjustments are accessible from the LCD.

Four navigation buttons and a separate Enter key allow the user to navigate the firmware menu on the LCD. Separate buttons have been provided for frequently used functions.

Common feed interfaces are offered as standard and isolation is provided at all RF interfaces.

A range of RF hardware options is offered to meet specific system requirements.

## FEATURES

- Menu Driven LCD for user friendly monitor and control
- Front Panel or Remote Operation
- 2 line x 40 character LCD
- Parallel I/O; Form C Contact Closure Outputs & Opto-Isolated Inputs
- RS-232/485 Serial Interface for Remote M&C
- Ethernet Port
- Removable Power Supply
- 1 Rack Unit height to maximize cabinet space
- Audible alarms
- Field programmable firmware
- Windows™ based remote M&C Software

## AT A GLANCE

The front panel displays the Mute and Online statuses of the Rack Mount SSPA, and allows monitoring of the following fault states:

- Summary
- Voltage
- Temperature
- Current
- Power Supply

## OPTION

- DC Operation

[Request A Quote](#)

# Remote Control Panel

## RCP2-1000-RM

### For Rack Mountable SSPAs

#### RCP2-1000 Front Panel Description

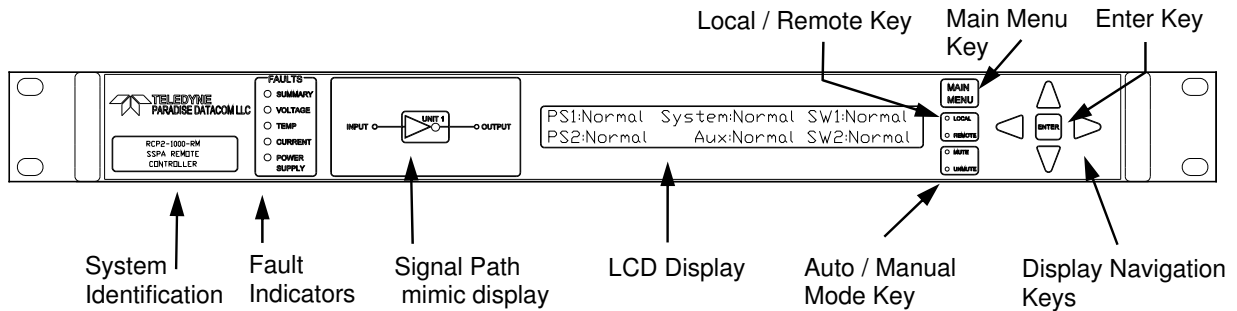

#### General Specifications

Characteristic	Specification
Configurations	RCP2-1000-RM; Remote Control Panel for Rack Mount and High Power Outdoor SSPAs
Serial Communications	RS-232 / RS-485 2-wire
Parallel I/O Status Outputs Control Inputs	Form C Relay Contacts (10 sets) Contact Closure to Ground
AC Input Power	85-265 VAC, 47-63 Hz, 1 A max, >0.93 power factor
Mechanical Dimensions	1.75 in. H x 19 in. W x 13.3 in. D [1 RU] 45 mm H x 483 mm W x 338 mm D
Weight	5 lb. (2.3 kg)
Environmental Temperature	0 - 50° C

#### Rear Panel Connectors and Pin Identification

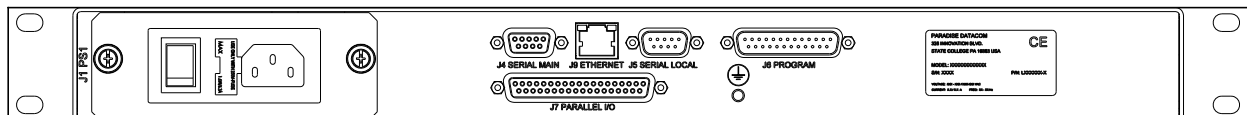

The RCP2-1000-RM includes two serial communications ports (J4 and J5). The Main Serial Port (J4) and Ethernet Port (J9) allow remote communication with a personal computer. The Local Serial Port (J5) allows a serial interface with a remote Rack Mount SSPA. Interface parameters are set by internal RCP hardware and cannot be reconfigured by user.

In addition, the RCP2-1000-RM features a 37-pin Parallel I/O port that contains a series of contact closures for monitoring remote SSPA faults as well as opto-isolated inputs for controlling some of the SSPA functions. Inputs react on the closure to ground.

The following tables show the pin outs for the Main Serial Port (J4), Local Serial Port (J5) and Parallel I/O Port (J7).

# Remote Control Panel

## RCP2-1000-RM

### For Rack Mountable SSPAs

#### Main Serial Port (J4) Pin Outs

Pin	Function
1	RS485 TX+ (HPA Transmit +)
2	RS485 TX- (HPA Transmit -)/RS232 TX
3	RS485 RX+ (HPA Receive -)/RS 232 RX
4	RS485 RX- (HPA Receive +)
5	GND
6	Service Request 1 Form C relay NC contact (Closed on HPA Summary Fault)
7	Service Request Common Form C relay common contact
8	Service Request 2 Form C relay NO contact (Opened on HPA Summary Fault)
9	120 Ohm termination (must be connected to pin 4 in order to enable termination)

#### Local Serial Port (J5) Pin Outs

Pin	Function
1	RS485 RX+
2	RS485 RX-
3	RS485 TX-
4	RS485 TX+
5	GND
6,7,8	Not Used
9	120 Ohm termination (must be connected to pin 1 in order to enable termination)

#### Ethernet Port (J9) Pin Outs

Pin	Function
1	TX+
2	TX-
3	RX+
6	RX-
4,5,7,8	GND

# Remote Control Panel

## RCP2-1000-RM

### For Rack Mountable SSPAs

#### J7, Parallel I/O Connector Pin-out

Pin #	Function Description
1	Closed on Power Supply Fault Form C relay NC
2	Open on Power Supply Fault Form C relay NO
20	Power Supply Fault Common
3	1. Standalone mode. Closed on Auxiliary Fault 2. 1:1 Redundancy Mode. Closed on Automatic switchover mode. Form C relay NC
21	1. Standalone Mode. Open on Auxiliary Fault 2. 1:1 Redundancy Mode. Closed on Manual switchover mode. Form C relay NO
22	Auxiliary Fault\Auto-Manual Common
4	Open on Mute. Form C Relay NC
5	Closed on Mute. Form C Relay NO
23	Mute Status Common
6	Closed on BUC Fault. Form C Relay NC
24	Open on BUC Fault. Form C Relay NO
25	BUC Fault Common
7	Closed on High Temperature Fault. Form C Relay NC
8	Open on High Temperature Fault. Form C Relay NO
26	High Temperature Fault Common
9	1. Standalone mode. Closed on Regulator Low Voltage Fault 2. 1:1 Redundancy Mode. Closed on HPA Standby. Form C relay NC
27	1. Standalone Mode. Open on Regulator Low Voltage Fault. 2. 1:1 Redundancy Mode. Closed on HPA Online Mode. Form C relay NO
28	Regulator Low Voltage Fault\Standby-Online Common
10	Closed on DC Current Low Fault. Form C Relay NC
11	Open on DC Current Low Fault. Form C Relay NO
29	DC Current Low Fault Common
12	Closed on Low Output RF Fault. Form C Relay NC
30	Open on Low Output RF Fault Form C Relay NO
31	Low Output RF Fault Common
17	Mute/Unmute toggle input. 50mS Closure to ground to activate
35	SSPA Standby input. 50mS Closure to ground to activate
36	RCP Local/Remote toggle. 50mS Closure to ground to activate
37	Fault clear. 50mS Closure to ground to activate
19	Ground
34, 33, 32, 18, 16, 15, 14, 13	Reserved. Make No Connection.