

## 1200-04 IF Processor

The 1200-04 IF Processor consists of a transmit and receive side. The receive side consists of one IF signal passing through an Automatic Gain Control (AGC) amplifier and then split into three output signals each having variable attenuators to adjust their levels via front panel multi-turn potentiometers. The AGC amplifier adjusts a **-95 to -15 dBm**, 50 to 90 MHz IF input signal to a **-30 dBm, +5, -15 dB** output. A front panel output port provides a monitor signal directly out of the AGC amplifier, and front panel potentiometers adjust the attenuation (between 0 and **20 dB**) to each of the three output signals, DIG1RX, FDMRX, and DIG2RX.

The transmit side consists of three transmit IF signals combined into one. DIG1TX, FDMTX, and DIG2TX signals each pass through individual attenuators controlled via front panel potentiometers and a switch that is controlled remotely through a DB9 connector or locally with three SPDT switches located on the front panel. A SPDT switch on the front panel selects either REMOTE or LOCAL operation. A local override feature is included such that when the REMOTE/LOCAL switch is left in the LOCAL position, the override pin on the DB9 can be set to override the LOCAL control and allow for REMOTE control.

DIG1 and DIG2 on both transmit and receive sides are 75Ω in/out while FDM on both transmit and receive sides are 50Ω in/out. When power is removed from the 1200-04, the FDM TX and FDMRX signals pass through to the output. IF connectors are **TNC** female. The 1200-04 is housed in a 1RU x 14" deep chassis and powered by a 100-240 ±10% VAC, 47-63 HZ input power supply.

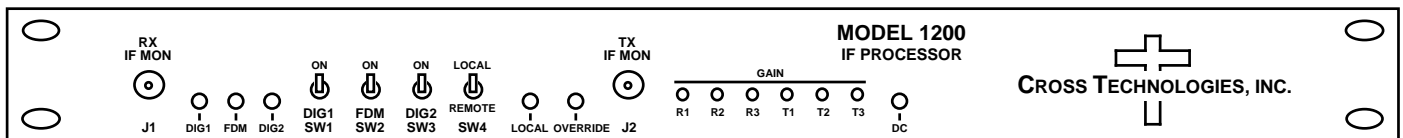

**Front Panel**

### EQUIPMENT SPECIFICATIONS\*

#### RX Input Characteristics

Impedance/RL	50Ω/18 dB
Frequency	50 to 90 MHz
Level range	<b>-15 to -95 dBm</b>
1dB compression	<b>-10 dBm</b>

#### RX Output Characteristics

Output Impedance/RL	50Ω,75Ω /18 dB
Monitor/AGC Out Level	<b>-30dBm, +5, -15 dB</b>
Level Range, Nominal	<b>-30 to -50 dBm</b>

#### RX Channel Characteristics

Gain, AGC	<b>-25 to +45 dB</b>
Gain adjustment	0 to <b>-20 dB</b>
Frequency Response	± 1.0 dB

#### TX Input Characteristics

Input Impedance/RL	50Ω,75Ω /18 dB
Frequency	50 to 90 MHz
Level range	-20 to +5 dBm

#### TX Output Characteristics

Impedance/RL	50Ω/18 dB
Level range	+5 to -20 dBm
1 dB compression	+10dBm

#### TX Channel Characteristics

Gain adjustment	0 to -30 dB
Frequency Response	± 1.0 dB
Group Delay, max	± 5 ns, max

#### TX Switch Characteristics

Isolation, Switch off	≥ 60dB
Isolation, Port to Port	≥ 50dB, all "ON"
Switch time	≤10 milliseconds

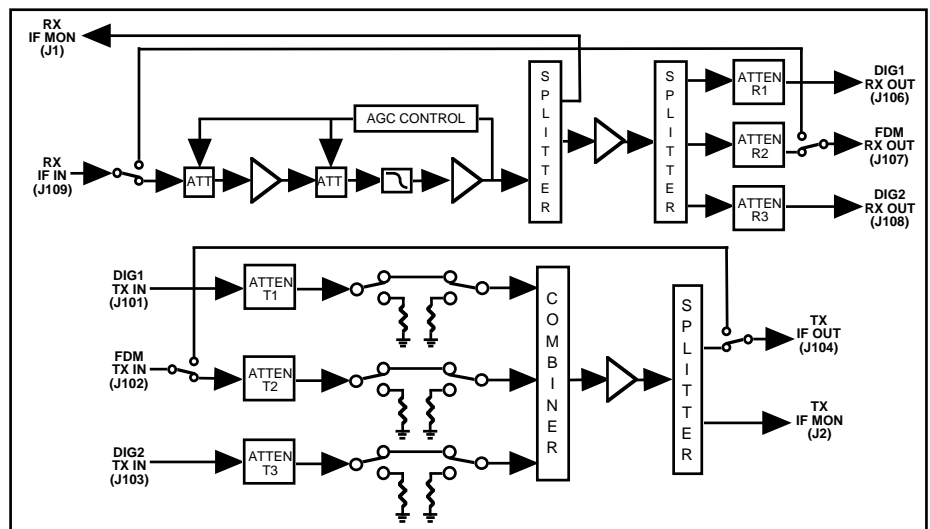

**Block Diagram**

#### Controls/Indicators

DIG1TX, FDMTX, DIG2TX	Green LEDs and SPDT switches
LOCAL/REMOTE	Red LED and SPDT switch
OVERRIDE	Yellow LED
POWER	Green LED

#### Other

IF Connectors	<b>TNC</b> (female)
Connector, DC, Control	DB9 (female)
Size,	19 inch 1RU chassis X 14.0" deep
Power	100-240 ± 10% VAC, 47-63 Hz, 30 watts max

\*10°C to 40°C; Specifications subject to change without notice