

2009-138 Downconverter, 13.75 - 14.5 GHz

The 2009-138 Downconverter converts a 13.75 - 14.5 GHz signal to 950 - 1700 MHz with a low side local oscillator (LO) (non-inverted spectrum) for loop-back applications. Featuring low phase noise and high stability, this unit is used to down convert "clean" (having only this frequency) 13.75 - 14.5 GHz signals to 950 - 1700 MHz for test purposes. The 13.75 - 14.5 GHz input is mixed with a synthesized local oscillator (LO) signal to 950 - 1700 MHz. The mixer output is applied to the output **amplifier** providing a nominal gain of **+25 dB**. Connectors are 75Ω type-F (female) for the 950 - 1700 MHz output and 50Ω type-N (female) for the RF input. Front panel LEDs light when DC power is applied (green) and when a PLL alarm occurs (red). DC power is provided by the LNB voltage from the receiver under test or by an external wall mount power supply (**option -P or -P4**). The 2009 can be mounted on an 1 3/4" X 19" rack mount panel (**option -R**).

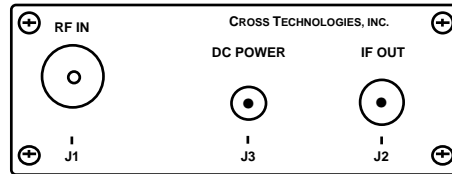
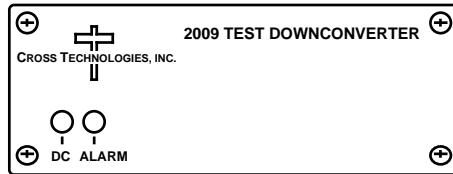

Front and Rear Panels

EQUIPMENT SPECIFICATIONS*

Input Characteristics

Impedance / Return Loss 50Ω / 12 db
 Frequency 13.75-14.5 GHz
 Level **-50 to -35 dBm**

Output Characteristics

Impedance / Return Loss 75Ω / 12 db
 Frequency 950 to 1700 MHz
 Level **-25 to -10 dBm**

Output 1 dB compression

0 dBm

Channel Characteristics

Gain at band center **+25 dB ±3 dB**
 Spurious Response <-40 dBC, 950-1700 MHz out
 Spectrum Sense Non-inverting
 Frequency Response ± 2 dB, 950-1700 MHz; ± 0.5 dB, any 10 MHz increment

Synthesizer Characteristics

LO Frequency 12.80 GHz
 Frequency Accuracy ± 2.5ppm max

Phase Noise @ F (Hz) >	100Hz	1kHz	10kHz	100kHz	1MHz
dBC/Hz	-60	-75	-85	-100	-110

Indicators

DC Power Green LED
 Alarm Red LED

Other

RF In Connector Type-N (female), 50Ω
 IF Out Connector Type-F (female)
 Size, Bench Top 4.7" wide X 1.75" high X 6.5" deep
 Size, Rack Mount (-R) 19" standard chassis, 1.75" high X 7.0" deep (optional)
 Power +15 to +18 VDC, 250 ma on RF Out (Wall mount power supply unit optional)

Options

-M Type N RF, 50Ω BNC L-band out
-P 120 VAC Wall Power Supply, +15 VDC
-P4 100-240 ± 10% VAC Wall Power Supply, +15 VDC
-R 1RU Rack Mounting
-C Power Supply not included. Requires Cross 2000-01 Power Supply
-W42 Alarm Contact Terminal Strip, Dry Contact, NC-C-NO Terminations

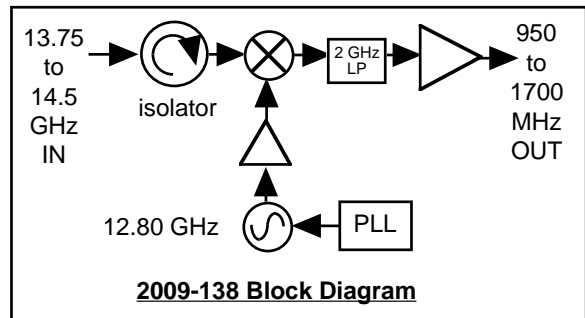

2009-138 Block Diagram

*+10°C to +40°C; 2000 meters max elevation; 80% max humidity; Specifications subject to change without notice.

