

284-0X Series L-Band Splitters

The Model 284-0X RF Splitters are five or nine way, 950 - 2050 MHz, 0 dB gain splitters providing excellent RF characteristics. Each splitter has a monitor connector on the front panel and four or eight outputs on the back panel. A SiDactor surge suppressor on the RF input protects against high voltage transients. On the front panel, a green LED indicates the presence of DC voltage. Up to three 284s can be mounted on an 1 3/4" X 19" rack mount panel (**option -R1, -R2, or -R3**).

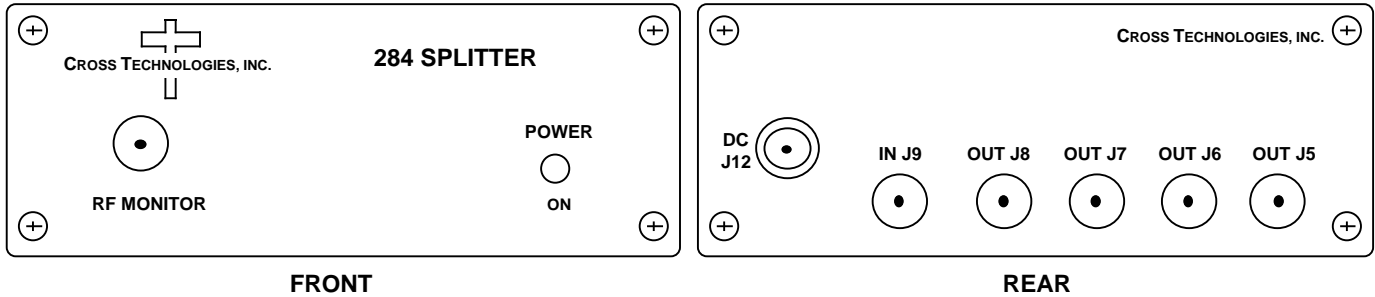

284-05 Front and Rear Panels

EQUIPMENT SPECIFICATIONS*

Input Characteristics

Input Impedance 75Ω
 Return Loss 12dB min, 14dB typ
 Input Level -20 dBm total maximum

Output Characteristics

Impedance 75Ω
 Return Loss 12dB min, 14dB typ

In-Band Characteristics

Gain 0 dB ± 1.0 dB
 Frequency Response ± 1.0 dB, 950-2150 MHz;
 ± 0.5 dB, any 20 MHz increment
 Port to Port Isolation > 18dB, 20dB typ

Indicators

Power Green LED indicates DC voltage prior to diode OR

Other

Surge Suppressor SiDACTOR
 RF connectors Type F (female)
 Power 115 VAC wall mount power supply
 Size (Bench Top) 4.7" wide x 1.75" high X 6.5" deep

Options

-R1,-R2, or -R3 Rack mounting (mounted on a 19-inch standard (1RU) panel, 1.75" high x 7.0" deep)
 -C No wall mount power supply (use 2000-02 model power supply)
 -P2 **100-240 ±10% VAC** wall mount power supply
 -D 50Ω BNC (RF), 50Ω BNC (IF) STD
 -W9 10MHz pass through (J9 to J8)

Models

284-05 One 5-way Splitter
 284-09 One 9-way Splitter

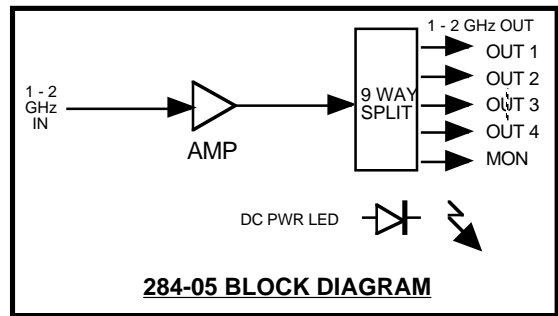

284-05 BLOCK DIAGRAM

*10°C to 40°C; Specifications subject to change without notice

