

**1582-71,72 RF SWITCH**

The **1582-71** provides Auto, Manual or Remote relay switching between CH1 and CH2 RF signals. Alarm conditions on CH1 and CH2 are either a contact closure to ground or an open (selectable). The logic controls two separate RF switches, X and Y. The **1582-72** has two independent switches. Switching logic can be selected as follows:

1) CH1 Prime Mode - Switches from CH1 to the CH2 only if CH1 alarms and CH2 is good. Switches back when CH1 no longer in alarm or both CH1 and CH2 are bad.

2) Latch to CH2 Mode - Switches to CH2 if CH1 alarms and CH2 is good. Latches to CH2. Push Manual Reset or ground Remote Reset pin to return to CH1 if it has no alarm.

3) Minimum AUTO switching, Initial Channel Select (ICS) Mode- Switch stays on channel last selected by Manual or Remote selection after return to AUTO. AUTO switching occurs only if current channel alarms and other channel clear.

When power is lost and on power up (as alarms at power up dictate), channel 1 is selected. The Manual Select switch and (when in AUTO) contact closures to Remote Select pins, select CH1 or CH2 independent of alarms. LEDs indicate alarms. LEDs and closures to ground indicate switch conditions for CH1, CH2 and REMOTE or MANUAL operation. Redundant power supplies.

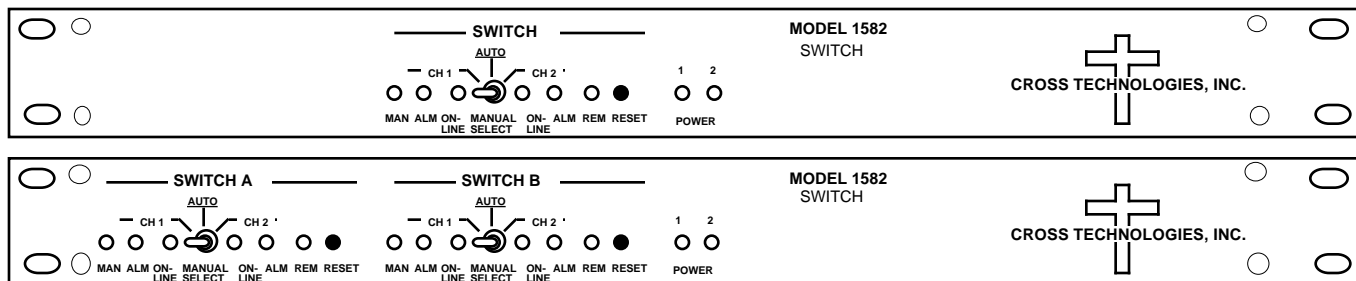

**1582-71,72 RF SWITCH**

**1582-71,72 Specifications**

**Switch Characteristics**

Impedance	75 ohms
Type	Relay
Isolation	>65 dB DC to 10 MHz >50 dB to 1.0 GHz; >40 dB to 1.5 GHz
Switch time	10 milliseconds
Insertion Loss	1 dB to 1.0 GHz; 1.5 dB to 2.0 GHz
Configuration	DPDT

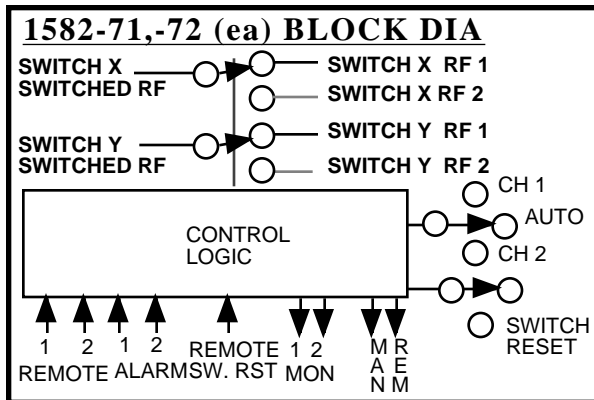

**Controls and Indicators**

Manual Select	Manually select CH1, CH2
SWITCH RESET	Resets to CH1 in latch mode, Also Resets REMOTE
HISTORY RESET	Resets alarm history (prior occurrence of alarms now cleared) LEDs only
LEDS (*=Closures)	CH1*, CH2* ON-LINE, ALARM, ALARM HISTORY, POWER; MANUAL*; REMOTE*

**Other**

Connectors	Terminal Strip (alarms and controls), 75 ohm BNC, female (RF)
Mechanical	19 inch standard chassis 1.75"high X 12" deep
Power	Redundant power supplies; 90 - 260 VAC, 47 -63 Hz, 30 watts

\*+10 to +40 degrees C; 2000 meters max elevation; 80% max humidity; Specifications subject to change without notice

