

## 1582-15,-16 Data Switches

The 1582-15 Data Switch provides Auto, Manual, or Remote relay switching between CH1 and CH2 clock or data signals (RS232C or RS422). Alarm conditions are either if data is lost for a preset 0.1 to 0.9 seconds on CH1, CH2 or with external alarm contact closures. The 1582-16 contains two switches in one chassis. Switching logic can be selected as follows:

1. CH1 Prime Mode - Switches from CH1 to the CH2 only if CH1 alarms and CH2 is good. Switches back when CH1 no longer in alarm or both CH1 and CH2 are bad.
2. Latch to CH2 Mode - Latches to CH2 if CH1 alarms and CH2 is good. Return to CH1 only when Manual Reset switch is pushed or Remote Reset pin is grounded and if no alarm on CH1.
3. Minimum AUTO switching, Initial Channel Select (ICS) Mode - Switch stays on channel last selected by Manual or Remote selection after return to AUTO. AUTO switching occurs only if current channel alarms and other channel is clear.

If power is lost or first applied (as alarms at power up dictate), CH1 is selected. The Manual Select switch and (when in AUTO) contact closures to Remote Select pins, select CH1 or CH2 independent of alarms. LEDs and closures indicate alarms and switch selection of CH1 or CH2 and REMOTE or MANUAL operation. The units are powered by redundant power supplies.

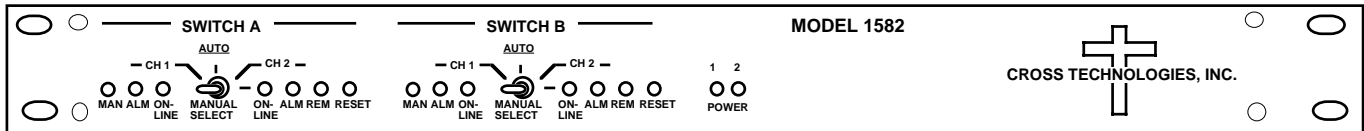

**1582-16 Front Panel**

### EQUIPMENT SPECIFICATIONS\*

#### Data Characteristics

Input/Output RS422 or RS232C  
 Data Rate 512 kbps max  
 Connector DB9 (female)

#### Switch Characteristics

Type Relay  
 Isolation > 40 dB  
 Switch Time ≤ 10 ms  
 Contact Resistance ≤ 10Ω, < 1Ω typ.  
 Configuration DPDT  
 Pins Switched 3, 4, 8, 9  
 Pins Connected 5 (GND)  
 Switch after alarm 0.1 to 0.9 (selectable)

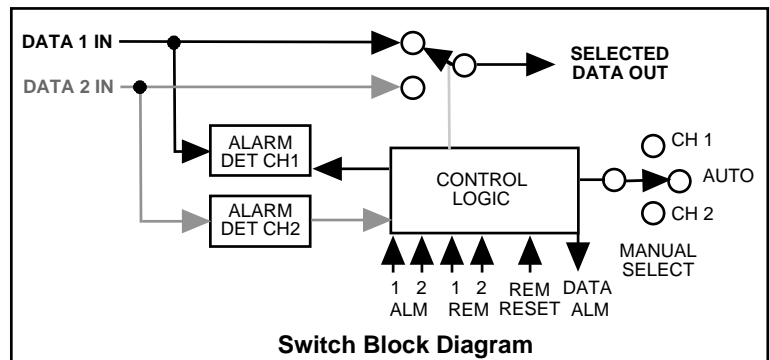

**Switch Block Diagram**

#### Controls, Indicators

Manual Select Switches between manual or automatic operation  
 Switch Reset Resets to CH1 if it is good and switch in latch mode; also resets REMOTE & returns to AUTO  
 ON-LINE (CH1,CH2) Green LEDs  
 MANUAL Red LED  
 ALARM (CH1,CH2) Red LEDs  
 POWER (1,2) Green LEDs  
 REMOTE Yellow LED

#### Other

Size 19 inch standard chassis 1.75" high X 12.0" deep  
 Power 90 - 260 VAC, 47 - 63 Hz, 30 watts max.

\*+10°C to +40°C; 2000m max elevation; 80% max humidity; Specifications subject to change without notice

