

Series 2083-1721 Agile L to L Translator

2083-1721 Agile L to L Translator - The 2083-1721 Agile L to L Translator converts a 1350-1700 MHz block to 1800-2150 MHz block with no spectrum inversion, low group delay and flat frequency response. The 1350-1700 MHz input is mixed with synthesized local oscillator (LO) signals, first to 3100 MHz center frequency and finally to the 1800-2150 MHz block output. Multi-function push button switches select the input level and gain. Frequency translation, input level, and gain (0 to +20 dB, selectable in 1 dB steps) settings appear on the LCD display. Front panel LEDs light when DC power is applied (green) or a PLL alarm occurs (red). Connectors are BNC female for RF input and output and for **(optional)** external 10 MHz reference (+3± 3 dBm in). The 2083-1721 is housed in an 1 3/4" X 19" X 16" deep rack mount chassis. **Option -H** provides a 0.01 ppm reference.

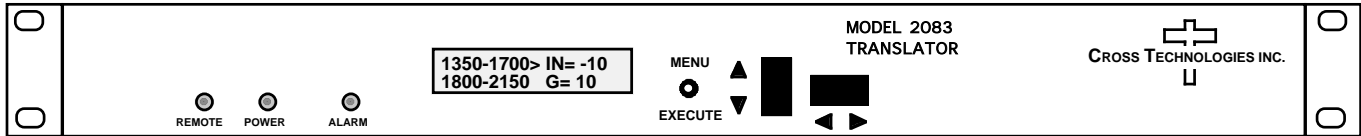

2083-1721 Agile L to L Translator

EQUIPMENT SPECIFICATIONS*

Input Characteristics

Input Impedance/RL 75 Ω/12 dB
 Frequency, 1350-1700 MHz
 Input Level -10 to **-30 dBm**
 Input 1 dB compression 0 dBm

Output Characteristics

Impedance/RL 75 Ω/12 dB
 Output Level, Range -10 to **-30 dBm**
 Output 1 dB compression 0 dBm
 Frequency 1800-2150 MHz

Channel Characteristics

Gain 0 to +20 ± 1 dB, selectable in 1 dB steps
 Frequency Response ± 1.0 dB, 350 MHz bandwidth; ± 0.5 dB, any 36 MHz increment
 Spurious Response <-45 dBC in band ; < **-50 dBm** out of band
 Group Delay, max 0.01 ns/MHz², parabolic, 0.03ns/MHz, linear, 1 ns ripple any 36 MHz BW
 Frequency Sense Non-inverting

Synthesizer Characteristics

Frequency Accuracy ± 1 ppm max over temp: Optional, High Stability (± 0.01 ppm) Option -H
 Reference 10 MHz Internal; Internal/External selectable is Option -E

Phase Noise @ F (Hz) >	100	1K	10K	100K	1M
dBC/Hz	-65	-70	-80	-90	-100

Controls, Indicators

Frequency Translation Setting shown on LCD display
 Input Level Selection pushbutton switches; setting shown on LCD display; Set to composite input level
 Gain Selection pushbutton switches; setting shown on LCD display; Set to 0 to +20 dB (-10 dBm max out)
 DC Power; PLL Alarm Green LED; Red LED

Other

Connectors RF In and Out and (optional) external 10 MHz reference In, BNC, female, 75 ohm
 Connector, Alarm DB9 - NO or NC contact closure on Alarm
 Size 19 inch standard chassis 1.75" high X 16.0" deep
 Power 100-240 (±10%) VAC, 47-63 Hz, 30 watts max.

OPTIONS

- E External 10 MHz reference In
 - D BNC, female, 50 ohms for L-Band In and Out
 - H High Stability (± 0.01 ppm) internal reference

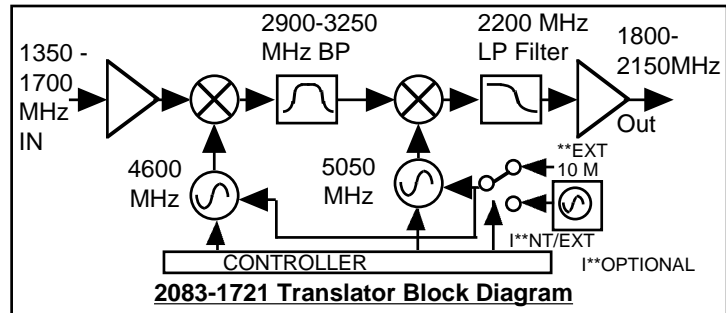

2083-1721 Translator Block Diagram

*+10 to +40 degrees C; Specifications subject to change without notice

