

4115-41-310 Ka-band Block Upconverter, Weather Resistant

The 4115-41-310 Ka-band Block Upconverter converts **1.00 - 2.00 GHz** up to 27.5 - 31.0 GHz in four selectable fixed bands. Front panel LEDs provide indication of DC Power and PLL Alarms. The L-band to RF gain is +30 dB. Connectors are 2.92mm for RF Out, SMA for the external reference input and reference output and Type N (all female) for the L-band input. Gain, band select, and internal 10 MHz frequency are controlled by the Ethernet M&C. In AUTO, the 10 MHz reference stays in external if the external level is in the +2 to +8 dBm range. It is powered by a 100-240 ± 10% VAC power supply, and mounted in a 8"W X 6"H X 16"D Weather Resistant enclosure.

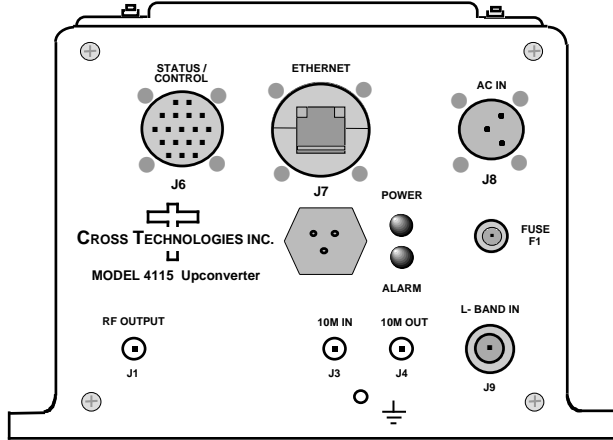

***Weather Resistant** enclosures are designed to be water resistant for installation in an outdoor enclosure/ antenna hut OR mounted outdoors on an antenna assembly at their specified temperature ranges. They are designed to be located "out in the elements" (water, sleet, snow, etc.) but they are *not* designed to be "submerged under" water.

If an extended temperature range is required, there is an **Extended Temperature** option (**Option W21**; -30°C to +60°C) available at an additional cost. Contact Cross for quote.

EQUIPMENT SPECIFICATIONS**

Input Characteristics

- Impedance/Ret. Loss: 50Ω/14 dB
- Frequency: **1.00 to 2.00 GHz**
- Noise Figure, Max.: 20 dB max gain
- Input Level range: -40 to -15 dBm

Output Characteristics

- Impedance/Ret. Loss: 50 Ω /14 dB, **Mute & UnMute**
- Frequency (GHz): BAND 1 27.5 to 28.5 GHz, BAND 2 28.0 to 29.0 GHz, BAND 3 29.0 to 30.0 GHz, BAND 4 30.0 to 31.0 GHz
- Output Level Range: -15 to 0 dBm
- Output 1 dB comp.: +10 dBm, **max gain**
- Mute**: >60 dB @ 0 dBm output

Channel Characteristics

- Gain at F_c: +30 ± 3 dB, (+30 to 0 dB variable in 0.5 ± 0.5 dB steps)
- Spurious, Inband: **F > F_c ± 1; ≤ -60 dBC**, -15 to -5 dBm out; **Over 27.5 to 31.0 GHz band**
- Spurious, Inband**: **F ≤ F_c ± 1; ≤ -50 dBC**, **Power supply related and reference sidebands: Over 27.5 to 31.0 GHz band**
- Spurious, Out of band: **≤ -60 dBC; Gain = +15, output = -2dBm; Over 10 - 27.5 GHz and 31.0 - 40 GHz bands**
- Intermodulation: <-50 dBC for two carriers at 4 MHz spacing, each at -5 dBm out
- Frequency Response: ± 2 dB, over RF band; **± 1.5 dB, 120 MHz BW; ± 0.5 dB, 10 MHz BW**, Frequency Sense - Non-inverting

LO Characteristics

- LO Frequency: Band Specific
- Frequency Accuracy: ± 0.05 ppm max over temp internal reference; **Aging ≤ 22 Hz/24 hours at constant temp**; ext. ref. input
- 10 MHz level In/Mon: +2 to +8 dBm in; Monitor Output = input level ± 1.0 dB, 50 ohms

Phase Noise @ F (Hz) >	10	100	1K	10K	100K	1M	10M	100M
dBC/Hz	-32	-65	-75	-84	-95	-105	-114	-114

Controls, Indicators

- Gain, Band, 10M Freq.: Gain, band select, and internal 10 MHz frequency via Ethernet M&C or Status/Control Connector
- PLL Alarm: Red LED, External Contact Closure
- Power: Green LED

Connectors*	Connector Part #	Mating Connector Part #	Additional Connector Specifications*		
Status/Control Connector	MS3112E14-18S	MS3116F14-18P	RF Out	L-Band	10MHz
Ethernet Connector/RJ45	RJF21B	RJF6G	2.92mm, Type K (Female) 50Ω	Type N (Female) 50Ω	SMA (Female) 50Ω
AC Input Connector**	CL1M1102	CL1F1101			

*All Cable Connectors are Weather Resistant

Other

- Size: 8" Wide X 6" High X 16" Deep, Weather Resistant* Enclosure
- Power: 100-240 ± 10% VAC, 47 - 63 Hz, 25 watts maximum

*+0 to +50 degrees C; Specifications subject to change without notice.

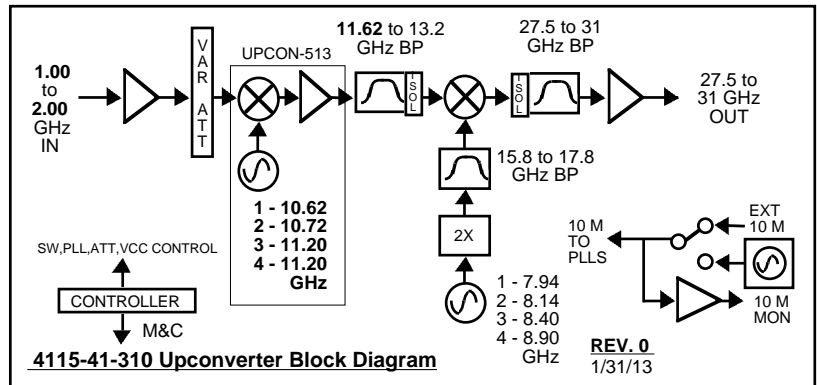

Request A Quote