

3116-125 Block Downconverter, 12.2 - 12.75 GHz to 0.95 - 1.50 GHz

The 3116-125 Downconverter converts 12.2 - 12.75 GHz to 0.95 - 1.50 GHz (non-inverted) with a 11.25 GHz local oscillator. The maximum gain is $+35 \pm 2$ dB and is adjustable in 0.5 ± 0.5 dB steps. Front panel LEDs provide indication of Remote operation, PLL Alarm and DC Power. Gain and internal/external/Auto reference frequency selection are controlled by front panel switches or remote selection (via RS-232C/485, standard; Ethernet Optional) and are viewable on the LCD Display. Connectors are SMA female for the RF and BNC female for the L-Band and external reference input and reference output. In AUTO, the 10 MHz reference stays in external if the external level is $+1$ to $+8$ dBm. The 3116 is powered by a 100-240 \pm 10% VAC power supply, and housed in a 1 3/4" X 19" X 14" rack mount chassis.

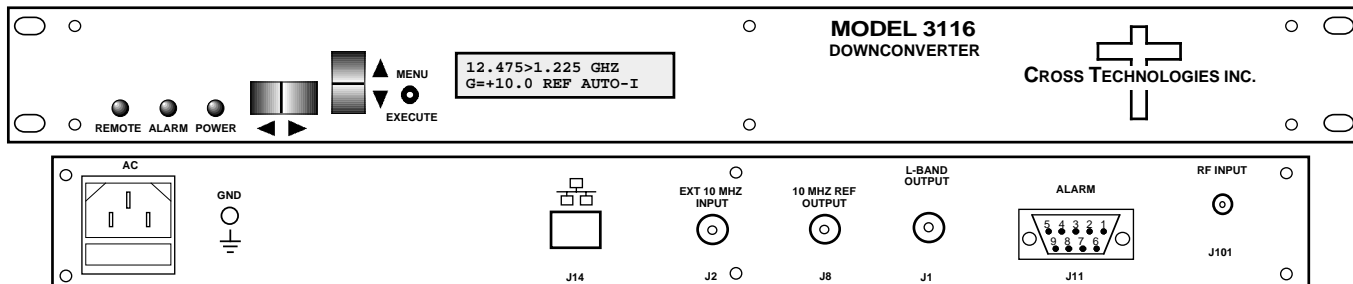

EQUIPMENT SPECIFICATIONS*

Input Characteristics (RF)

- Impedance/Return Loss 50Ω/14 dB
- Frequency 12.2 to 12.75 GHz
- Noise Figure, Max. 15 dB max gain
- Input Level range -55 to -35 dBm
- Input 1 dB compression -25 dBm

Output Characteristics (L-Band)

- Impedance/Return Loss 50Ω/14 dB
- Frequency 0.95 to 1.50 GHz
- Output Level Range -20 to 0 dBm
- Output 1 dB compression $+10$ dBm at max. gain

Channel Characteristics

- Gain, max; adjustment $+35$ dB ± 2 dB, max. gain @ Fc; 30 dB adjustment in 0.5 ± 0.5 dB Steps
- Image Rejection > 60 dB, min
- Spurious, In Band **-60 dBC, signal related; < -60 dBm, signal independent; 0 dBm out & max gain; (0.95-1.50 GHz Out)**
- Spurious, Out of Band < -50 dBm (**0.5-0.95 GHz and 1.50-2.5 GHz Out**)
- Intermodulation < -55 dBC for two carriers each at -10 dBm out
- Frequency Response ± 1.5 dB, **0.95 -1.50 GHz out; ± 0.5 dB, 40 MHz BW**
- Frequency Sense Non-inverting

LO Characteristics

- LO Frequency 11.25 GHz
- Frequency Accuracy ± 0.01 ppm max over temp internal reference; ext. ref. input
- 10 MHz In/Out Level **Input $+1$ to $+8$ dBm in; Output 3 ± 3 dBm, w/ Auto-detect**

Phase Noise @ F (Hz) >	10	100	1K	10K	100K	1M
Standard dBC/Hz	-55	-70	-80	-85	-100	-110

Controls, Indicators

- Gain; Ext Ref Selection Direct readout LCD; pushbutton switches or remote
- Pwr; Alarm; Rem; Mute Green LED; Red LED; Yellow LED; Yellow LED
- Remote RS232C/RS485/422, 9600 baud (Ethernet Optional)

Other

- RF Connector SMA (female), 50Ω
- L-Band Connector BNC (female), 50Ω
- 10 MHz Connectors BNC (female), **75Ω, works with 50 or 75 ohms**
- Alarm/Remote Conn. DB9 - NO or NC contact closure on Alarm
- Size 19 inch standard chassis 1.75" high X 14.0" deep
- Power 100-240 \pm 10% VAC, 47 - 63 Hz, **30** watts max.

Front and Rear Panel (Shown with optional Ethernet)

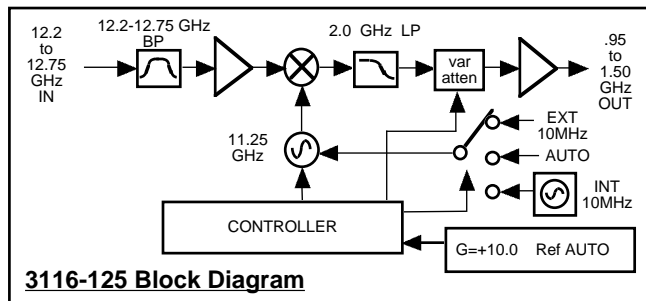

Available Options

W31 0 to $+50$ degrees C operation

Remote M&C Ethernet Options

- W8 - Ethernet w/web browser Interface
- W18 - Ethernet w/web browser & SNMP (MIB)
- W28 - Ethernet w/direct TCP/IP Interface
- W828 - Ethernet, W18 + W28**

Connector Options

- N - 50Ω N-type (RF), 75Ω BNC (L-BAND)
- NF - 50Ω N-type (RF), 75Ω F-type (L-BAND)
- NN - 50Ω N-type (RF), 50Ω N-type (L-BAND)
- S7 - 50Ω SMA (RF), 75Ω BNC (L-BAND)
- SF - 50Ω SMA (RF), 75Ω F-type (L-BAND)
- SN - 50Ω SMA (RF), 50Ω N-type (L-BAND)
- SS - 50Ω SMA (RF), 50Ω SMA (L-BAND)

Contact Cross for other options

*10°C to 40°C; Specifications subject to change without notice

