

2116-55 Block Downconverter, 5.5 - 6.0 GHz

The 2116-55 Downconverter converts 5.5 - 6.0 GHz to 1.2 - 1.7 GHz with low phase noise and flat frequency response. Frequency translation is via a 7.2 GHz local oscillator. Front panel LEDs provide indication of DC Power, External 10 MHz, and PLL Alarm. The gain is +35 dB. Connectors are Type N female for the RF and BNC female for the L-Band and external reference input and reference output. A three-way switch controls which 10 MHz reference is being used. In the INT position, the internal reference is used, in the EXT position, the external reference is used, and in the AUTO position, the internal reference is used unless a 3 dBm ± 3 dB, 10MHz reference signal is connected to the external reference input. The 2116 is powered by a 100-240 ±10%VAC power supply, and mounted in a 1 3/4" X 19" X 14" rack mount chassis.



Front Panel

EQUIPMENT SPECIFICATIONS*

Input Characteristics (RF)

Impedance/Return Loss 50Ω/14 dB
 Frequency 5.5 to 6.0 GHz
 Noise Figure, Max. 15 dB max gain
 Input Level range -55 to -35 dBm
 Input 1 dB compression -25 dBm

Output Characteristics (L-Band)

Impedance/Return Loss 50Ω/14 dB
 Frequency 1.2 to 1.7 GHz
 Output Level Range -20 to 0 dBm
 Output 1 dB compression +10 dBm

Channel Characteristics

Gain +35 dB ±2 dB
 Image Rejection > 60 dB, min
 Spurious, In Band SIGNAL RELATED<-60 dBC in band, 0 dBm out; SIGNAL INDEPENDENT,<-60 dBm
 Spurious, Out of Band <-50 dBm
 Intermodulation <-55 dBC for two carriers each at -10 dBm out
 Frequency Response ±1.5 dB, 1.2 to 1.7 GHz out; ± 0.5 dB, 40 MHz BW
 Frequency Sense Inverting

LO Characteristics

LO Frequency 7.2 GHz
 Frequency Accuracy ± 0.01 ppm max over temp internal reference; ext. ref. input
 10 MHz In/Out Level 3 dBm, ± 3 dB
 Phase Noise @ Freq | 100Hz 1kHz 10kHz 100kHz 1MHz
 dBC/Hz | < -70 < -80 < -85 < -100 < -110

Controls, Indicators

Ext 10 MHz Yellow LED, indicates external 10 MHz reference selected (rear panel DPDT switch)
 Power Green LED
 PLL Alarm Red LED, External contact closure

Other

RF Connector N-type (female), 50Ω
 L-Band Connector BNC (female), 50Ω
 10 MHz Connectors BNC (female), 50Ω/75Ω
 Alarm Connector DB9 - NO or NC contact closure on Alarm
 Size 19 inch standard chassis 1.7" high X 14.0" deep
 Power 100 - 240 ±10% VAC, 47 - 63 Hz, 45 watts max.

Available Options

Connectors/Impedance
 FN - 50Ω N-type (RF), 75Ω F-type (L-Band)
 M - 50Ω N-type (RF), 50Ω BNC (L-Band)
 N - 50Ω N-type (RF), 75Ω BNC (L-Band)
 NN - 50Ω N-type (RF), 50Ω N-type (L-Band)
 NS - 50Ω SMA (RF), 50Ω N-type (L-Band)

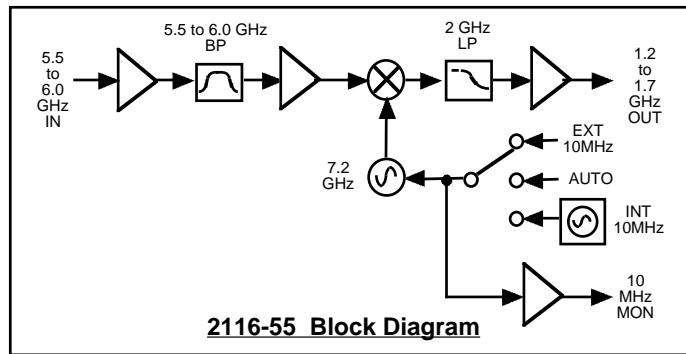

*10°C to 40°C; Specifications subject to change without notice

