

**2116-35 Block Downconverter, 3.4 - 4.2 GHz**

The 2116-35 Downconverter converts 3.4 - 4.2 GHz to 0.95 - 1.75 GHz with low phase noise and flat frequency response. Frequency translation is via a 5.15 GHz local oscillator. Front panel LEDs provide indication of DC Power, External 10 MHz, and PLL Alarm. The gain is +55 dB. Connectors are Type N female for the RF and BNC female for the L-Band and external reference input and reference output. A three-way switch controls which 10 MHz reference is being used. In the INT position, the internal reference is used, in the EXT position, the external reference is used, and in the AUTO position, the internal reference is used unless a 3 dBm  $\pm$  3 dB, 10MHz reference signal is connected to the external reference input. The 2116 is powered by a 100-240  $\pm$ 10% AC power supply, and mounted in a 1 3/4" X 19" X 14" rack mount chassis.



**Front Panel**

**EQUIPMENT SPECIFICATIONS\***

**Input Characteristics**

Impedance / Return Loss 50 $\Omega$  / 14 dB  
 Frequency 3.4 to 4.2 GHz  
 Noise Figure, max. 20 dB max gain  
 Input Level range -85 to -55 dBm  
 Input 1 dB compression -45 dBm

**Output Characteristics**

Impedance/Return Loss 50 $\Omega$  / 14 dB  
 Frequency 0.95 to 1.75 GHz  
 Output Level Range -30 to 0 dBm  
 Output 1dB compression +10 dBm

**Channel Characteristics**

Gain +55 dB  $\pm$ 2 dB  
 Image Rejection > 60 dB  
 Spurious, In Band < -60 dBC, 0 dBm out; < -60 dBm, signal independent  
 Spurious, Out of Band < -50 dBC  
 Intermodulation < -55 dBC for two carriers each at -10 dBm out  
 Frequency Response  $\pm$ 1.5 dB, over frequency band;  $\pm$  0.5 dB, 40 MHz BW  
 Frequency Sense Inverting

**LO Characteristics**

LO Frequency 5.15 GHz  
 Frequency Accuracy  $\pm$  0.01 ppm max over temp internal reference; ext. ref. input  
 10 MHz In/Out Level +3 dBm  $\pm$  3 dB  
 Phase Noise

@ Freq	100Hz	1kHz	10kHz	100kHz	1MHz
dBC/Hz	< -70	< -80	< -90	< -100	< -110

**Controls, Indicators**

Power Green LED  
 PLL Alarm Red LED, External contact closure  
 Ext 10 MHz Yellow LED, indicates external 10 MHz reference selected (rear panel DPDT switch)  
 10 MHz Reference 3-way Switch (selects INT, EXT, or AUTO mode)

**Other**

RF, L-Band Connectors N-type, BNC (female)  
 10 MHz Connectors BNC (female), 50 $\Omega$ /75 $\Omega$   
 Alarm Connector DB9 - NO or NC contact closure on Alarm  
 Size 19 inch standard chassis 1.75" high X 14" deep  
 Power 100 - 240  $\pm$ 10% VAC, 47 - 63 Hz, 45 watts max.

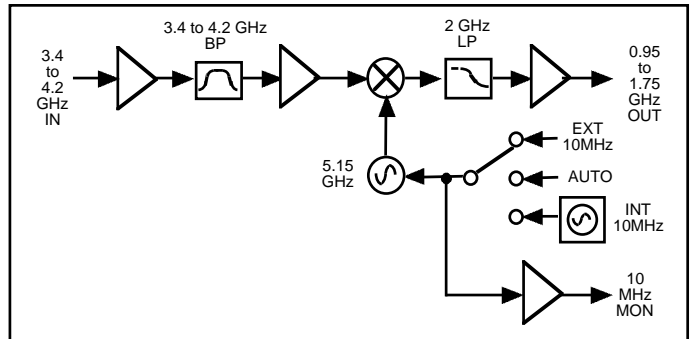

**Block Diagram**

**Available Options** (Connectors/Impedance)

S - 50 $\Omega$  SMA (RF), 50 $\Omega$  BNC (L-band)  
 FS - 50 $\Omega$  SMA (RF), F-type (L-band)  
 FN - 50 $\Omega$  N-type (RF), F-type (L-band)  
 N - 50 $\Omega$  N-type (RF), 75 $\Omega$  BNC (L-band)

\*0°C to 50°C; Specifications subject to change without notice

