

## 2116-38 Block Downconverter, 3.7 - 4.2 GHz, Non-Inverting

The **2116-38** Downconverter converts **3.7 - 4.2 GHz** to **0.95 - 1.45 GHz** with low phase noise and flat frequency response. **Dual conversion** frequency translation is via **9.05 GHz and 11.8 GHz local oscillators**. Front panel LEDs provide indication of DC Power, External 10 MHz, and PLL Alarm. The gain is +35 dB. Connectors are Type N female for the RF and BNC female for the L-Band and external reference input and reference output. A three-way switch controls which 10 MHz reference is being used. In the INT position, the internal reference is used, in the EXT position, the external reference is used, and in the AUTO position, the internal reference is used unless a 3 dBm ± 3 dB, 10MHz reference signal is connected to the external reference input. The 2116 is powered by a 100-240 ± 10% VAC power supply, and mounted in a 1 3/4" X 19" X 14" rack mount chassis.



**Front Panel**

### EQUIPMENT SPECIFICATIONS\*

#### Input Characteristics (RF)

Impedance/Return Loss 50Ω/18 dB  
 Frequency 3.7 to 4.2 GHz  
 Noise Figure, Max. 12 dB max gain  
 Input Level range -55 to -35 dBm  
 Input 1 dB compression -25 dBm

#### Output Characteristics (L-Band)

Impedance/Return Loss 50Ω/14 dB  
 Frequency 0.95 to 1.45 GHz  
 Output Level Range -20 to 0 dBm  
 Output 1 dB compression +10 dBm

#### Channel Characteristics

Gain +35 dB ±2 dB  
 Image Rejection > 60 dB, min  
 Spurious, In Band SIGNAL RELATED<-60 dBC in band, 0 dBm out; SIGNAL INDEPENDENT,<-60 dBm  
 Spurious, Out of Band <-50 dBm  
 Intermodulation <-55 dBC for two carriers each at -10 dBm out  
 Frequency Response ±1.5 dB, 950 -1750 MHz out; ± 0.5 dB, 40 MHz BW  
 Frequency Sense **Non-Inverting**

#### LO Characteristics

LO Frequency **9.05 GHz and 11.8 GHz**  
 Frequency Accuracy ± 0.01 ppm max over temp internal reference; ext. ref. input  
 10 MHz In/Out Level 3 dBm, ± 3 dB

Phase Noise @ F (Hz) >	100	1K	10K	100K	1M
dBc/Hz	-70	-80	-85	-100	-110

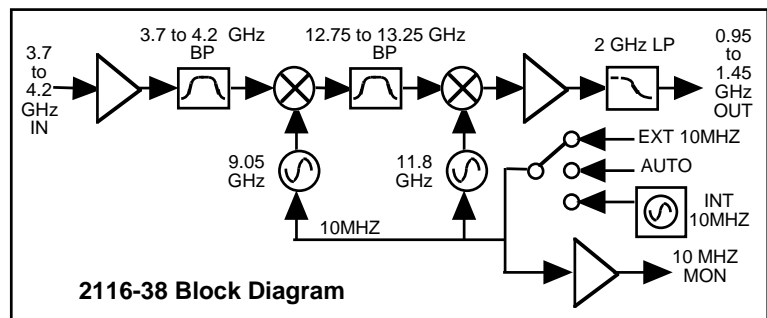

**2116-38 Block Diagram**

#### Controls, Indicators

Ext 10 MHz Yellow LED, indicates external 10 MHz reference selected (rear panel DPDT switch)  
 Power Green LED  
 PLL Alarm Red LED, External contact closure

#### Other

RF Connector N-type (female), 50Ω  
 L-Band Connector BNC (female), 50Ω  
 10 MHz Connectors BNC (female), 50Ω/75Ω  
 Alarm Connector DB9 - NO or NC contact closure on Alarm  
 Size 19 inch standard chassis 1.45" high X 14.0" deep  
 Power 100-240 ± 10% VAC, 47 - 63 Hz, 45 watts max.

#### Available Options

Connectors/Impedance  
 FN - 50Ω N-type (RF), 75Ω F-type (L-Band)  
 M - 50Ω N-type (RF), 50Ω BNC (L-Band)  
 N - 50Ω N-type (RF), 75Ω BNC (L-Band)  
 NN - 50Ω N-type (RF), 50Ω N-type (L-Band)  
 NS - 50Ω SMA (RF), 50Ω N-type (L-Band)

\*10°C to 40°C; Specifications subject to change without notice

