

2.4 and 2.5 Meter Nomadic Antennas

NOMADIC MILSAT

The ASC Signal 2.4/2.5 m Nomadic is a highly flexible antenna system designed to operate on almost any satcom band and in many configurations. The entire reflector structure consists of lightweight carbon fiber panels, with multiple mounting scenarios, and can be ordered in motorized or nonmotorized versions. With feeds available to address L-, C-, X-, Ku-, K-, Ka-, and Q-bands, as well as low PIM capable feeds, few applications are beyond its capabilities.

This antenna supports a variety of interchangeable feeds which are engineered for simple removal and replacement in the field. The reflector is constructed with a precision-formed honeycomb core and a carbon fiber skin which assures durability and high performance. The reflector is readily available in one-, three-, and nine-piece versions - all sharing common RF design components and performance capabilities.

The Nomadic is designed to be lightweight, with maximum stiffness, yet offers compact and highly robust components. The versatile architecture makes it ideal for launching highly divergent equipment applications using a single, flexible, modular and cost-effective equipment base.

Electronically engineered to operate at multiple frequencies, ASC Signal's 2.4/2.5 meter Nomadic is capable of transmitting and receiving signals under demanding wind loads and surviving winds up to 100 mph. Weighing less than 220 kg (480 lb), in fully motorized versions (including feeds), the tactical version can be deployed by two trained individuals within 30 minutes.



Features

- Multiple Versions available
- 2.4m with one-, three-, and nine-piece reflector panels
- 2.5m with one-piece reflector panel
- Motorized and non-motorized axes
- Pedestal, Tactical and Mobile Mounts
- Eight-case ISO shippable version
- Lightweight reflector , high accuracy tracking mount
- Interchangeable feed systems for quick field swaps
- Meets all applicable FCC, ITU and Mil-Spec standards
- Designed to comply with MIL-STD-810F
- Various trailer configurations are available
- Low PIM X-band available

2.4 and 2.5 Meter Nomadic Antennas

NOMADIC MILSAT



2.5M One Piece Reflector



2.4M Nine Piece Reflector on Tactical Mount
with Transit Cases

2.4 and 2.5 Meter Nomadic Antennas

The Nomadic Antennas are designed around a base configuration to provide modular flexibility and configurability. In addition, they are designed to be rugged and to allow for maximum compactability to withstand the demands and rigors of transport in military and commercial aircraft. The feeds are also palletized to allow for easy transport and for band changes in minutes.

RF Performances

	C-band	X-band	Ku-band	K-band	Ka-band	Q-band
Tx Gain (typ. Midband)	41.3	43.6	48.2	51.0	55.3	58.0
Rx Gain (typ. Midband)	37.6	43.3	47.3	47.4	52.0	52.1
G/T (typ. Midband) ¹	18.3	23.8	26.5	26.5	28.8	28.8
EIRP (Max Theoretical)	-	-	-	-	-	-
3dB Beamwidth Rx	2.09	1.23	0.79	0.76	0.44	0.40

¹G/T shown is typical for mid-band single thread, nominal temperature rated LNA connected directly to the feed flange and does not include post LNA contributions. See feed sheets for more details.

Environmental Performances

Operating Conditions (Typical)				
Pointing Accuracy	4 GHz	7.75 GHz	12 GHz	20 GHz
Typical (Degree RMS)				
Calm	0.18°	0.22°	0.19°	0.19°
Winds 30 gusting 45 mph	0.19°	0.24°	0.21°	0.24°
Typical (Degree Peak)				
Calm	0.27°	0.30°	0.26°	0.29°
Winds 30 gusting 45 mph	0.29°	0.35°	0.43°	0.80°
Wind Loading				
Survival	100 mph ballasted 125 mph stowed			
Temperatures				
Range	Operational -40°C to +60°C (-40°F to +140°F)		Survival -58°C to +71°C (-50°F to +160°F)	
Seismic				
	1G Vertical and Horizontal; 8.3 Richter; 11 Mercalli			
Solar Radiation				
	360 BTU/h/ft ² (1135 watts/m ²)			
Rain				
	Up to 10 cm/h (4 in/h)			
Relative Humidity				
	0% to 100%			

Shock	As encountered by Air, Ship, Rail and Truck	
Atmospheric	As encountered in moderately corrosive coastal and industrial environments	
Altitude	Operational	Survival
Range	Up to 12,000 ft	Up to 40,000 ft

Mechanical Performances

Reflector	Multi-Band Intergangeable		
Color	White (other color available)		
Material	Carbon Fiber		
Segments	One, Three, and Nine Segment Versions (2.4m) One Segment Version (2.5m)		
Feed Type	Prime Focus Offset		
Mount Type	EI over Az Pedestal		
Boom/Positioner Capacity			
Size Limit	38" x 14" x 12" (96cm x 36cm x 30cm) Boom		
Weight Limit	220 pounds Boom	330 pounds Positioner	
Overall Dimensions (stow)	L	W	H
2.4m One Piece Relector	131"	86"	24"
2.4m Three Pieces Relector	131"	97.2"	24"
2.4m Nine Pieces Relector	131"	97.1"	24"
2.5m One Piece Relector	137.6"	96.6"	24"
Stow Height	<24 inches		
Pointing Range			
Azimuth	±150° Continuous		
Elevation	0° to 90° of Boresight		
Polarization	±100°		
Maximum Travel Limits	User defineable within mechanical limits		
Operate Limits	Hardware and Software Settable		

2.4 and 2.5 Meter Nomadic Antennas

NOMADIC MILSAT

Electrical Specifications

Controller Type	Multi Axis Tracking Controller with Auto Acquisition Assist
Controller Package	Single Box Outdoor Motor Controller 3RU 19" EIA Rack Mounted Indoor Controller
Prime Power	Indoor 110-220 VAC 50/60 Hz (Universal) Outdoor 24 VDC, 120 VAC (Field Configurable)
Power Consumption	20A or less @ 24VDC, 5A @ 120VAC (est.)
Motor (Az, El, and Pol)	24 VDC
Remote IDU Interconnect	Ethernet
Remote Interface	Remote Operation Software, SNMP V1 & V2c
IDU/ODU IFL	Multi Mode Fiber Optic Cable
Optional Sensors	GPS, Compass, and Inclinometers
Angle Transducers	19 bit optical encoder
Angle Resolution	0.0010°
Positioning Accuracy	0.0050° (est)

Shipping Information

Packing Options	
Standard Commercial Domestic Pack	Included
Service and materials For Ocean Transport Packaging of 2.4/2.5M product	CRATE-24-OCEAN
Service and materials For Air Transport Packaging of 2.4/2.5M product	CRATE-24-AIR
Service and materials for enclosed crating a 2.4/2.5M product for transport	CRATE-24-PACK
Required Shipping Container	
Standard 20 ft land/sea container	Quantity 1

Shipping container information is given for basic configuration and may vary depending on the selected options, please contact ASC Signal for specific container loading plan.

2.4 and 2.5 Meter Nomadic Antennas

2.4m Dimensional Drawings

NOMADIC MILSAT

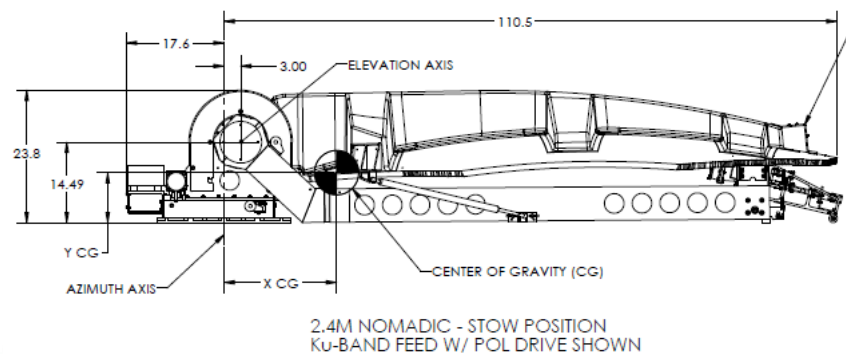
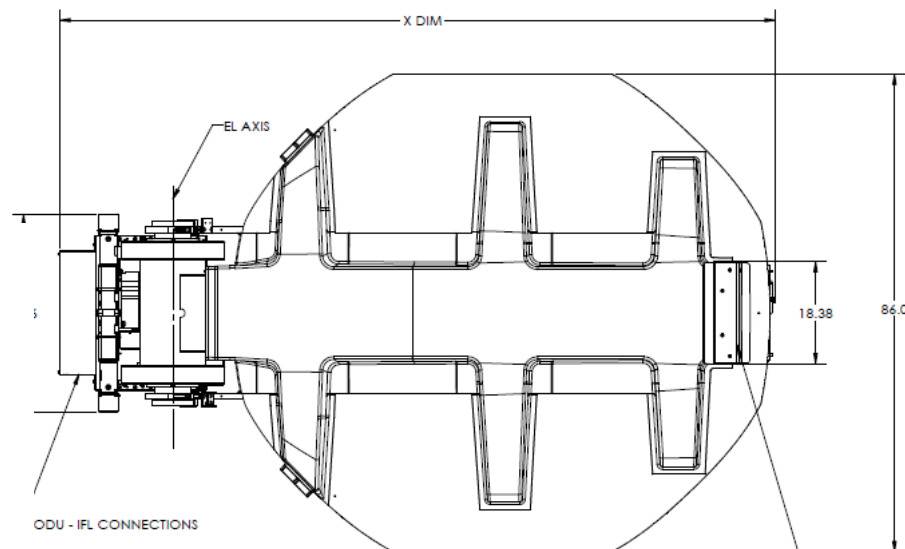
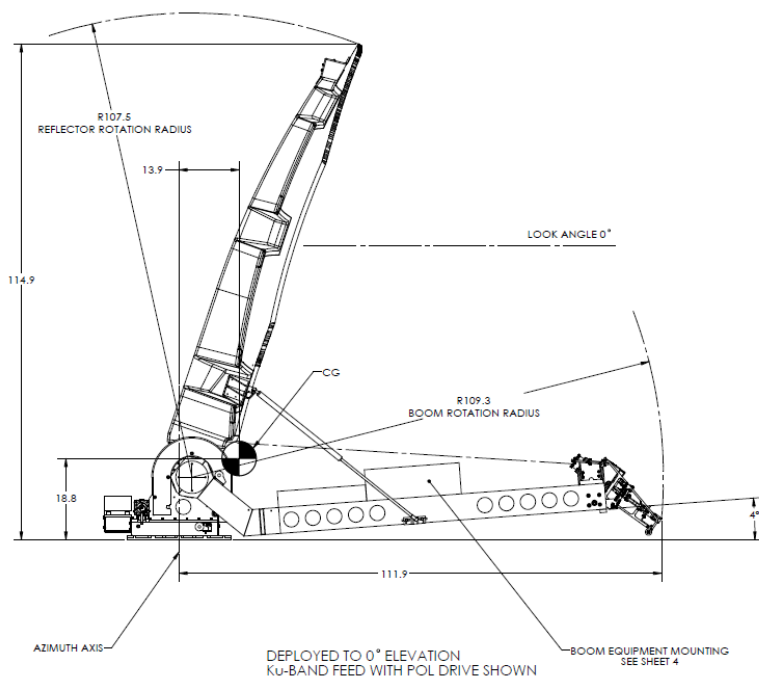

2.4 and 2.5 Meter Nomadic Antennas

2.5m Dimensional Drawings

NOMADIC MILSAT

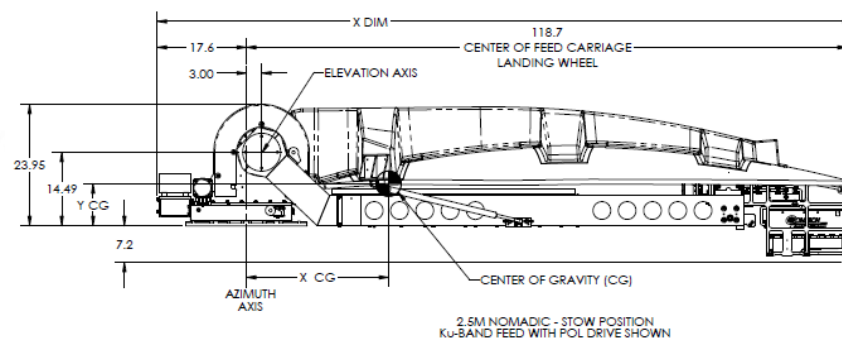
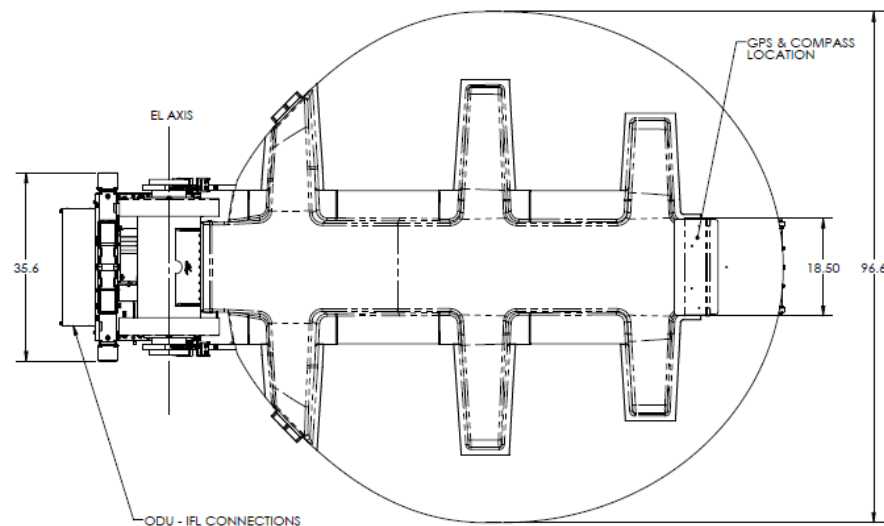
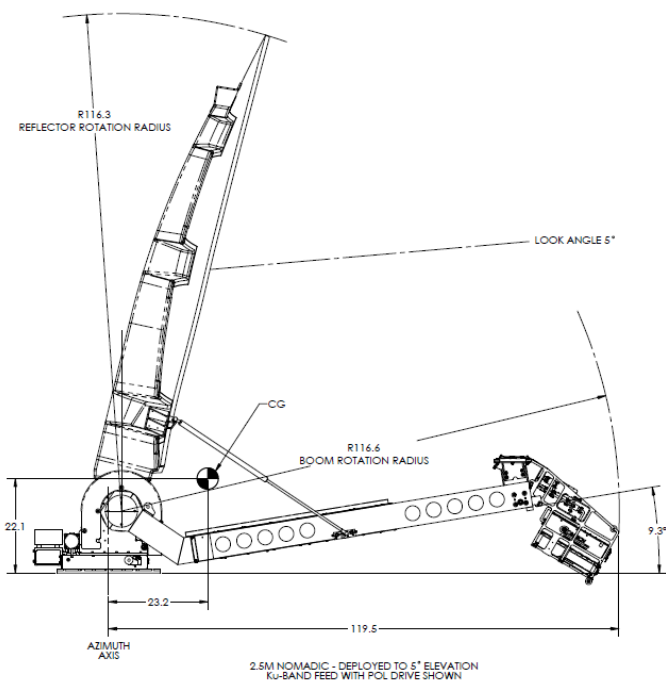

2.4 and 2.5 Meter Nomadic Antennas

2.4m Dimensional Drawings Ground Mount Pedestal

NOMADIC MILSAT

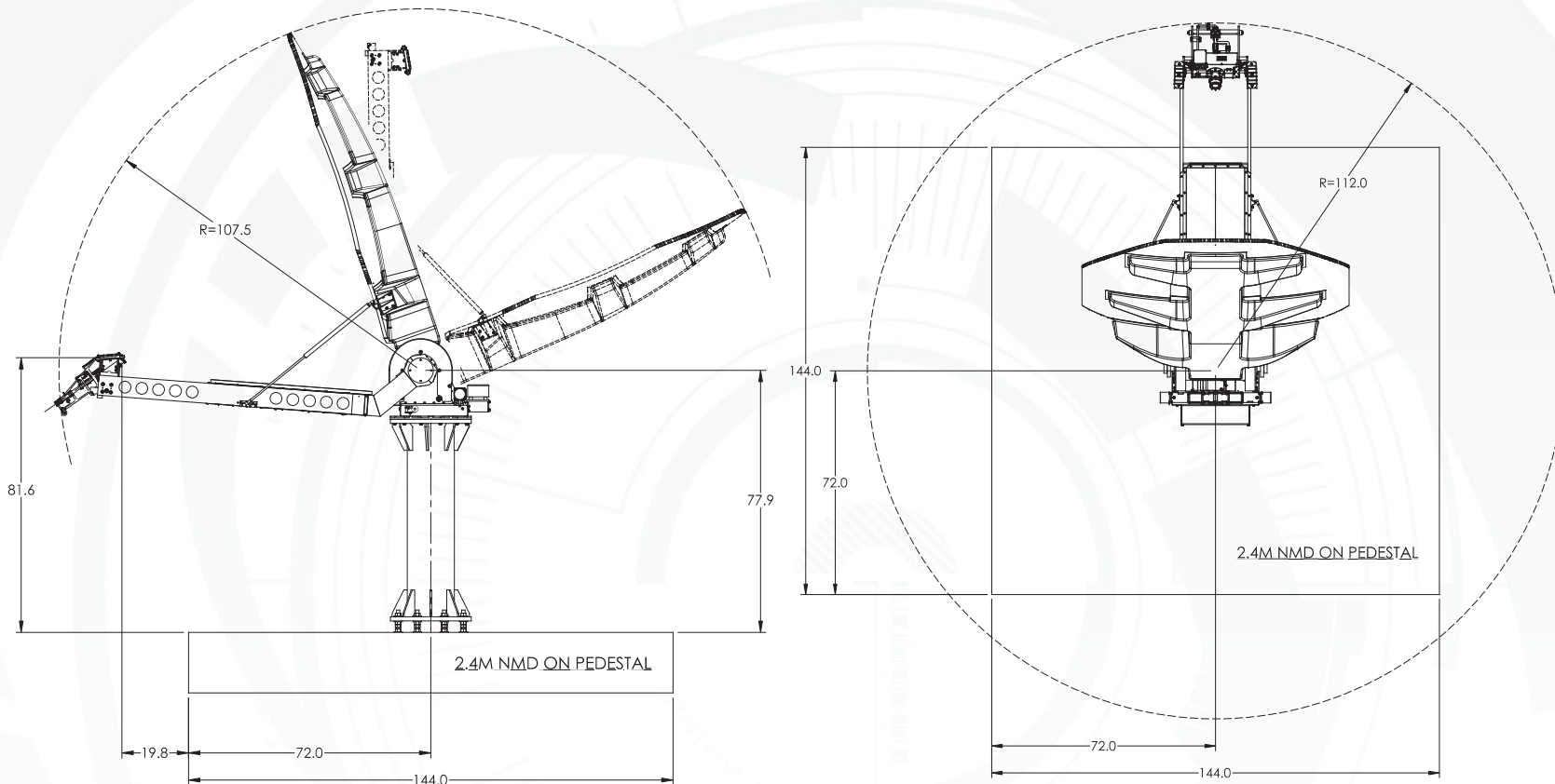

2.4 and 2.5 Meter Nomadic Antennas

2.5m Dimensional Drawings Ground Mount Pedestal

NOMADIC MILSAT

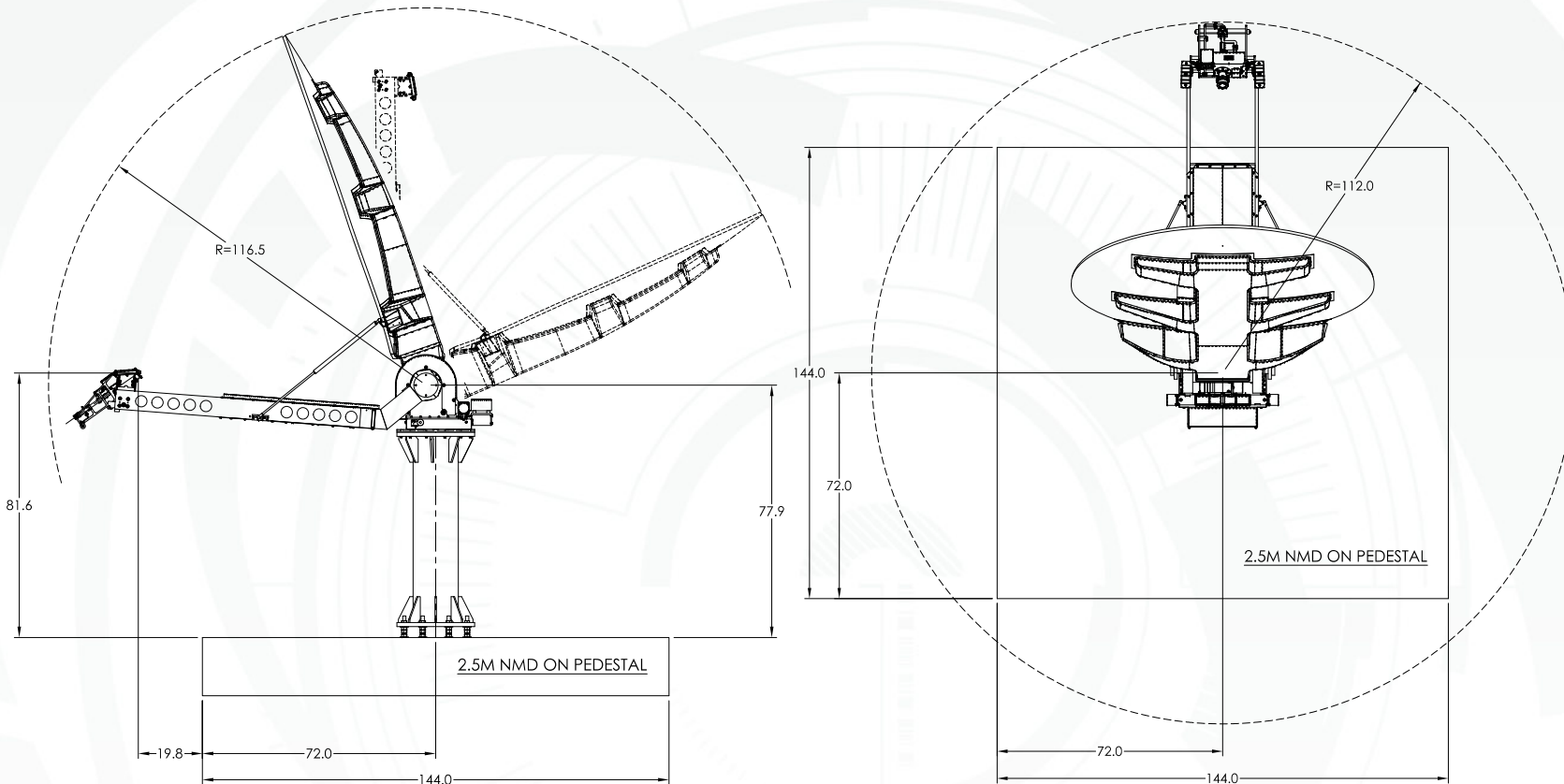

2.4 and 2.5 Meter Nomadic Antennas

2.4m and 2.5m Typical Foundation Design (with PEDMNT-4)

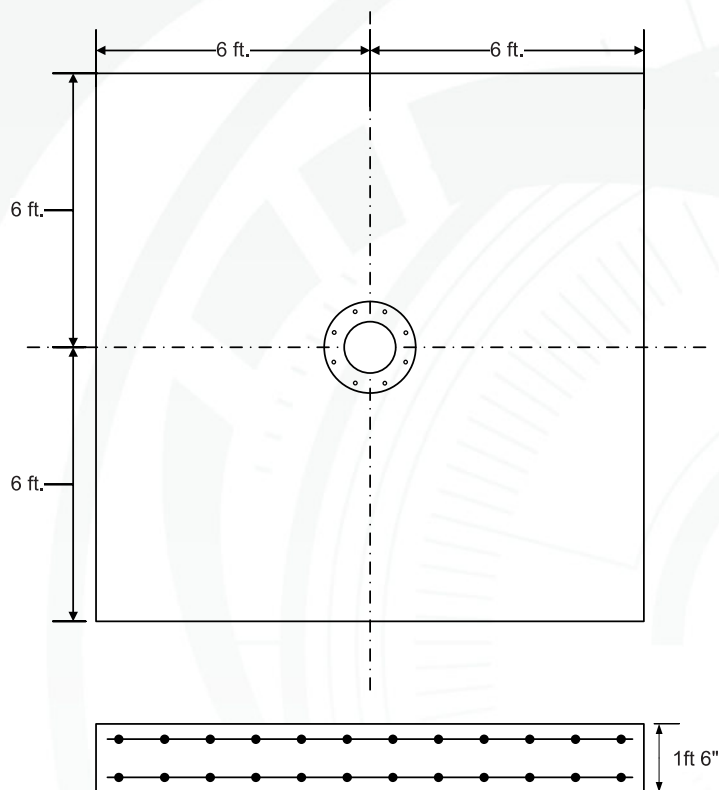

Foundation information are provided in bulletin 7588871 (2.4m) and 7588872 (2.5m), please contact ASC Signal.

Soil Bearing Capacity,	2000 lb/ft ² (9770 kg/m ²)
Reinforcing Steel,	821 lbs (372 kg)
Concrete Compressive Strength,	3000 psi (211 kg/cm ²)
Foundation Size:	(for specific standard soil and typical design)
Length	12 ft (3.66 m)
Width	12 ft (3.66 m)
Depth	1 ft 6 in (0.457 m)
Concrete Volume	8 yd ³ (6.1 m ³)

NOTE: Other typical foundation designs are available. Soil borings and foundation analysis should be performed by a qualified civil engineer.

2.4 and 2.5 Meter Nomadic Antennas

2.4m 9 Piece Tactical Mount Dimensional Drawings

NOMADIC MILSAT

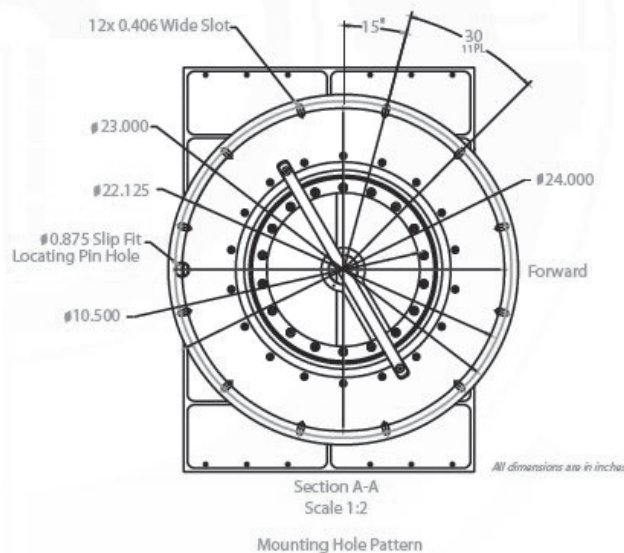
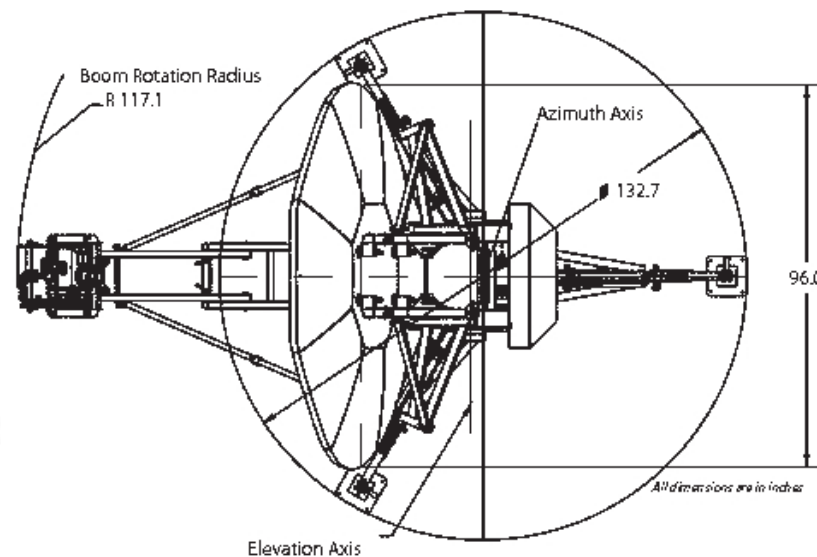
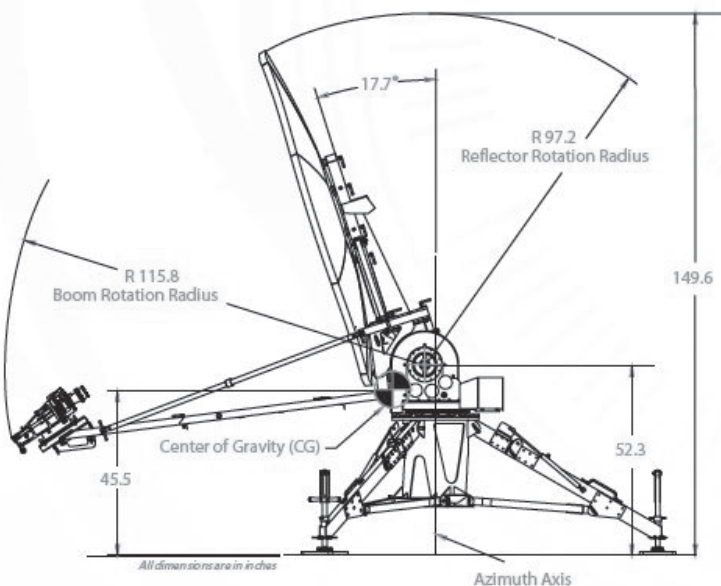

2.4 and 2.5 Meter Nomadic Antennas

2.4m & 2.5m Dimensional Drawings

NOMADIC MILSAT

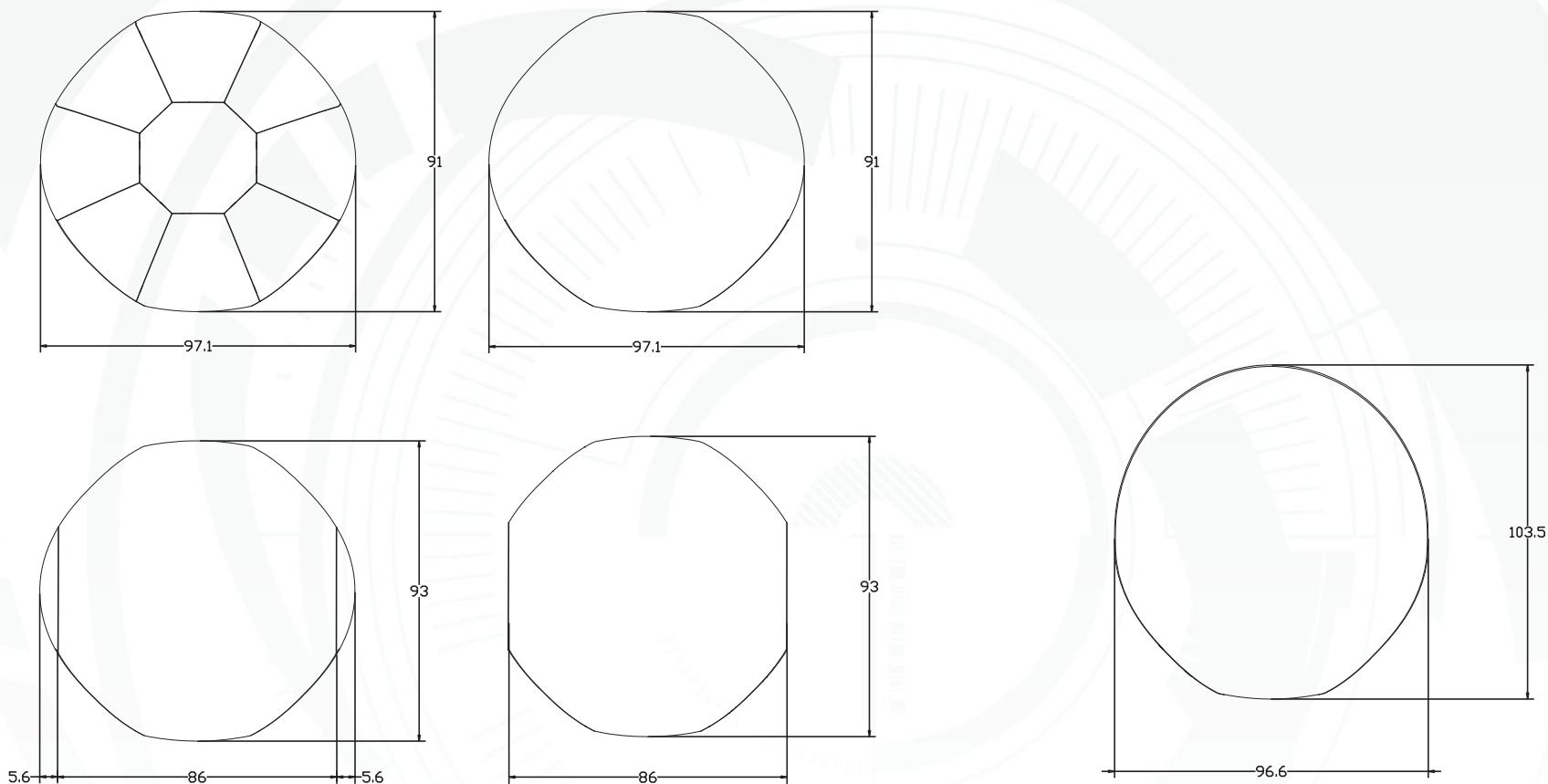

2.4m Reflector

2.5m Reflector

2.4 and 2.5 Meter Nomadic Antennas

NOMADIC MILSAT

Motorization

One motorization system is available for this antenna: the NGC tracking system that can support Steptrack, Smartrack and Ephemeris orbital tracking.

Motor Kit

Azimuth/Elevation Motor Kit is part of the motorizable positioner

Polarization Drive Kit (DC Step Motors)

Standard Temperature (> -20°C) NGC-PK24-24

Outdoor Unit Controller

Power 24VDC 5 AMPS NGC-ODU-NMD

Antenna controller, motorization and options are detailed in specific bulletins, please contact ASC Signal..

Antenna Configurations

Reflectors

Single Piece Lightweight 2.4 Meter Off-Set Feed Antenna Reflector	NMD-24-1
Three Pieces Lightweight 2.4 Meter Off-Set Feed Antenna Reflector	NMD-24-3
Nine Pieces Lightweight 2.4 Meter Off-Set Feed Antenna Reflector	NMD-24-9
Single Piece Lightweight 2.5 Meter Off-Set Feed Antenna Reflector	NMD-25-1
Single Piece Lightweight 2.5 Meter Off-Set Feed Low PIM Antenna Reflector	NMD-25-LP-1

Positioners

Tactical Tripod Mounting System - Motorizable	NMD-TAC-M
Tactical Tripod Mounting System - Manual	NMD-TAC-NM
Vehicle Mounting System - Motorizable , suitable for mounting on a vehicle, trailer, pedestal, or tactical mount	NMD-VEH-M
Vehicle Mounting System - Manual, suitable for mounting on a vehicle, trailer, pedestal, or tactical mount	NMD-VEH-NM

Motorization and NGC Options

Indoor	
NGC-IDU	NGC Rack Mounted Antenna Controller W/LCD Touch Panel
NGC-001	NGC-IDU Analog Telephone Modem
NGC-002	NGC-IDU Spectrum Analyzer Card, Analog
NGC-003	NGC-IDU DVB Receiver Card
NGC-RTX-2	NGC IDU, L-Band Internal Beacon Receiver
NGC-006	NGC-IDU Emergency Stop Button
NGC-007	NGC-IDU 10 Mhz Reference Source
NGC-008	NGC-IDU Redundant Power Supply
NGC-009	NGC-IDU Rack Slides
NGC-101	NGC-IDU Step Tracking Software
NGC-102	NGC-IDU Smartrack Software
NGC-103	NGC-IDU Predictive Track Software
NGC-104	NGC-IDU Full Tracking Capability Software
NGC-105	NGC-IDU Acquisition Assist
NGC-106	NGC-IDU Remote Access Software Package
NGC-107	NGC-IDU Spectrum Analyzer Enhanced User Interface
NGC-108	Receive Pattern Test Tool
NGC-115	Uplink Power Control Software Function
NGC-ULPC-INTFC	Uplink Power Control System Single Channel
NGC-ULPC-INTFC-2	Uplink Power Control System Dual Channel
Outdoor	
NGC-SEN-24-HA	Nomadic Sensor Kit, High Accuracy
RED11-x	Hub Mounted 1:1 LNA/LNB Redundancy Plate
RED12-x	Hub Mounted 1:2 LNA/LNB Redundancy Plate

2.4 and 2.5 Meter Nomadic Antennas

NOMADIC MILSAT

Feed Matrix 2.4 and 2.5m

C- BAND FEED SYSTEMS	PORT	CP	LP	Motorized	RX 3.625 - 4.2 GHz	TX 5.850 - 6.425 GHz
2CPC-24	2	X			X	X
2LPC-24-M	2	X	X	X	X	

X- BAND FEED SYSTEMS	PORT	CP	Low PIM	RX 7.25 - 7.75 GHz	TX 7.9 - 8.4 GHz
2CPXF-24	2	X		X	X
4CPX-24	4	X		X	X
2CPMX-24	2	X	X	X	X

Ku- BAND FEED SYSTEMS	PORT	LP	Motorized	RX 10.95- 12.75 GHz	RX 10.7 - 12.75 GHz	TX 13.75- 14.8 GHz
2LPKU-24-M	2	X	X	X		X
2LPKU-24-NM	2	X		X		X
4LPKU-24-M	4	X	X		X	X
4LPKU-24-NM	4	X			X	X

K- BAND FEED SYSTEMS	PORT	LP	Motorized	RX 10.7 - 12.75 GHz	TX 17.3 - 18.4 GHz
2LPKK-24-NM	2	X		X	X

KA- BAND FEED SYSTEMS	PORT	LP	CP	Motorized	RX 17.7 - 21.2 GHz	RX 20.2 - 21.2 GHz	TX 24.7 - 25.3 GHz	TX 27.5 - 31.0 GHz	TX 30.0 - 31.0 GHz
2CPKA-24-1	2		X			X			X
4CPKA-24-1	4		X		X			X	
4CPKA-24-2	4		X				X		
4CPWWKA-24	4		X			X	X		
4LPKA-24-1-NM	4	X			X			X	
4LPKA-24-2-NM	4	X				X	X		
4LPWWKA-24-NM	4	X				X	X		

Q- BAND FEED SYSTEMS	PORT	CP	Motorized	RX 20.2 - 21.2 GHz	TX 43.5 - 45.5 GHz
4CPQ-24	4	X		X	X

2.4 and 2.5 Meter Nomadic Antennas

NOMADIC MILSAT

Antenna Options and Spares

Anchor Bolt and Template Kits Option	
302689	Anchor Bolt and Template Kit for 2.4/2.5 Meter Nomadic with PEDMNT
Heating Options	
GSS-24-1	2.4M Passive Snow Shield Cover
SSH12K-24-1	2.4M 4KW Electric Heater System
WSS-IC-100	Interface Cable; 100ft
WSS-RMDP7	Rack Mounted Remote Monitor Panel
Color Options	
NMD-33510	Sandstone Color Painting for Reflector FS33510
NMD-34096	Olive Drab Color Painting for Reflector FS34096
NMD-NPN-LG	Custom Color Painting for Reflector
Other Options	
NMD-24-LP	LOW PIM Antenna Configuration & Range Certification Test Service
NMD-TAC-TCASE	Tactical System Transit Case for 2.4M
PEDMT-24	Pedestal Mount for 2.4/2.5 Meter; Galvanized
PEDMT-24-FSxxxxx	Pedestal Mount for 2.4/2.5 Meter; Podwer Coated to Match FS Color (xxxxx)
PEDMT-24-INT	Galvanized Pedestal Mount Interface Kit for 2.4/2.5 Meter
FTST	Feed System Testing

Tactical System Transit Case

NMD-TAC-TCASE Used with 2.4m nine piece reflector (approximate)

Equipment	Case	Case Dims (inches nominal)
7588954 Case Back Structure	1	101.80 x 39.90 x 20.79
7588813 Case Feed Boom	2	62.25 x 27.25 x 29.69
7588811 Case Platform Azimuth	3	44.00 x 44.00 x 18.00
7588812 Case Platform Elevation	4	42.75 x 30.75 x 27.34
7588925 Case Reflector 9 Pieces	5	55.00 x 43.00 x 52.69
7588938 Case Tripod Legs	6	84.43 x 28.43 x 43.81
7588936 Case Tripod Pedestal Column	7	37.38 x 37.38 x 38.43

NMD-FEED-TCASE-xx Single Feed Transit Case

Equipment	Case	Case Dims (inches nominal)
PN to be defined depends on feed system part number for foam cutout	8+	TBD

Request A Quote