

5.6 Meter ESA

Like all ASC Signal earth station antennas, the 5.6 Meter Earth Station Antenna provides high gain and exceptional pattern characteristics.

This antenna system is designed to address the stringent requirements of both the television broadcast industry and telecommunications network operators who demand unsurpassed flexibility and electrical performance in high-quality, cost-effective, and reliable packages.

The electrical performance and exceptional versatility provides the ability to configure the antenna with your choice of linearly- or circularly- polarized 2- or 4- port combining networks. That versatility is provided at the time of initial purchase, as well as in the future, as your satellite communication requirements evolve.

This antenna system is used worldwide in broadcast applications and high density data, voice and communications networks. The ASC Signal 5.6 meter earth station antenna features a computer-optimized dual reflector Gregorian optics system and close-tolerance manufacturing techniques.

This combination provides extremely accurate surface contour resulting in exceptionally high gain and closely controlled pattern characteristics. ASC Signal earth station antennas provide maximum durability with minimal maintenance.



Features

- 3 year warranty on all structural components
- FCC paragraph 25.209 for mandatory pattern requirements for 2 degree satellite spacing based on off satellite measurement at Ku- Band
- Configured for Ku- Band and K- Band transmit and receive
- Deep equipment enclosure for hub mount electronics

5.6 Meter ESA

Design Standards

Reflector	Aluminum painted with highly diffusive white paint
Ground Mount	Hot-dipped galvanized steel, per ASTM-A123 for structural steel.
Hardware	Sizes ≤ 3/8 in (9.5mm), stainless steel, passivated per MIL-F-14072-E300 Sizes ≥ 3/8 in (9.5mm), hot-dipped galvanized stainless steel, passivated per ASTM-A123

Environmental Performances

Operating Temperature	-40° to 52°C (-40° to 125°F)
Seismic (Earthquake)	1 G Vertical and Horizontal acceleration, Equivalent to a Richter Magnitude 8.3, and Grade 11 on the modified Mercalli Scale
Operational Winds	45 mph (72 km/h) Gusts to 65 mph (105 km/h)
Survival Winds	125 mph (200 km/h) in any stationary position of operation
Rain	4 in (102 mm) per hour
Solar Radiation	360 BTU/hr/ft ² (1135 Watts/m ²)
Relative Humidity	100%
Shock and Vibration	As encountered by commercial Air, Rail and Truck shipment.
Atmospheric Conditions	As encountered by Moderately Corrosive Coastal and Industrial Areas.

Mechanical Performances

The 5.6m Antenna mechanical general specifications and performances are listed in below table. Additional information, dimensions and layout may be provided by ASC Signal on a case-by-case basis.

Optics Type	Dual Reflector Gregorian
Reflector Material	Precision-Formed Aluminum
Reflector Segments	16
Mount Type	Az over El Tripod Mount

Antenna Pointing Range, Coarse/(Continuous)

Elevation:	5-90° (85°)
Azimuth:	180° (120°)
Polarization	180° (180°)

Hub/Enclosure Dimensions

Diameter	1.32 m (52 in)
Depth	1.17 m (46 in)

Shipping Information

Packing Options

Standard Commercial Domestic Pack	Included
Ocean Export Pack - For non-containerized, packed for seal against salt water spray	OCEANSHP-MD
Air Export Pack - For freighter aircraft shipments. Lower deck AirPack requires specialized bids	AIR EXPORT PACK-MD
Container Packaging	CNTPCK-MD

Required Shipping Container

Standard 20 ft land/sea container	Quantity 1
-----------------------------------	------------

Shipping container information is given for basic configuration and may vary depending on the selected options, please contact ASC Signal for specific container loading plan.

5.6 Meter ESA

Dimensional Drawings

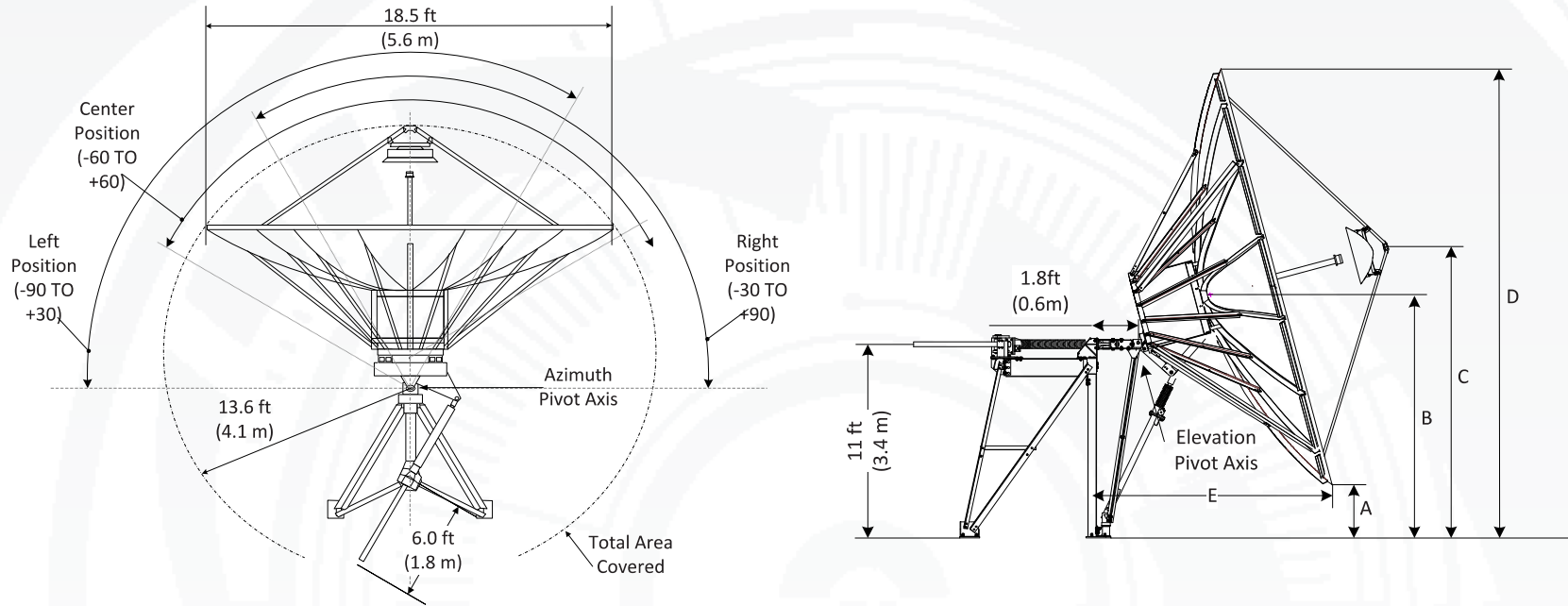

Top View

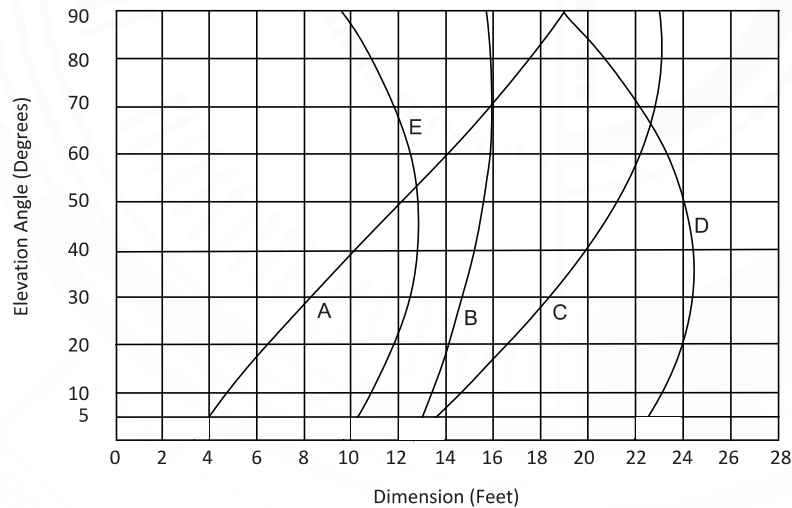

EARTH STATION ANTENNA

5.6 Meter ESA

Foundation, Typical Slab

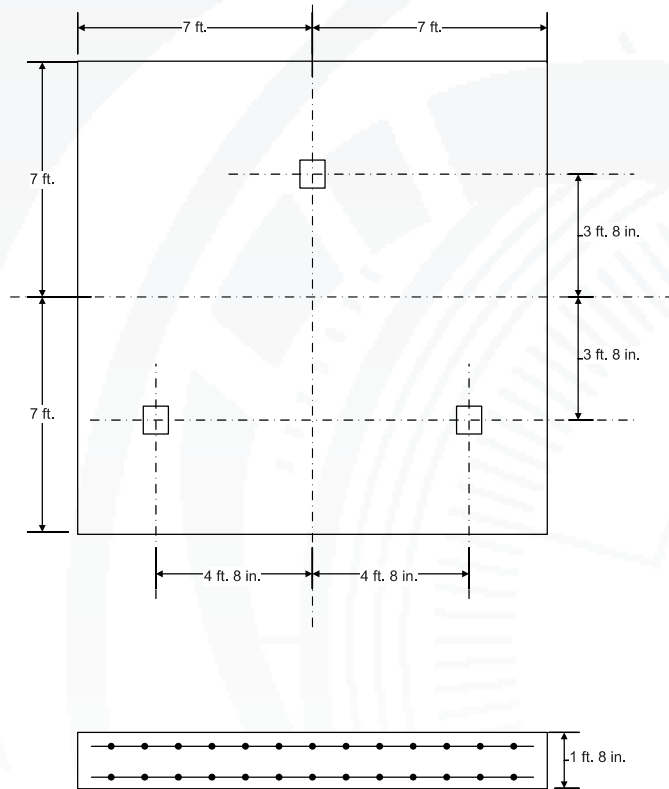

Foundation information are provided in bulletin 237029, please contact ASC Signal.

Typical Foundation Information

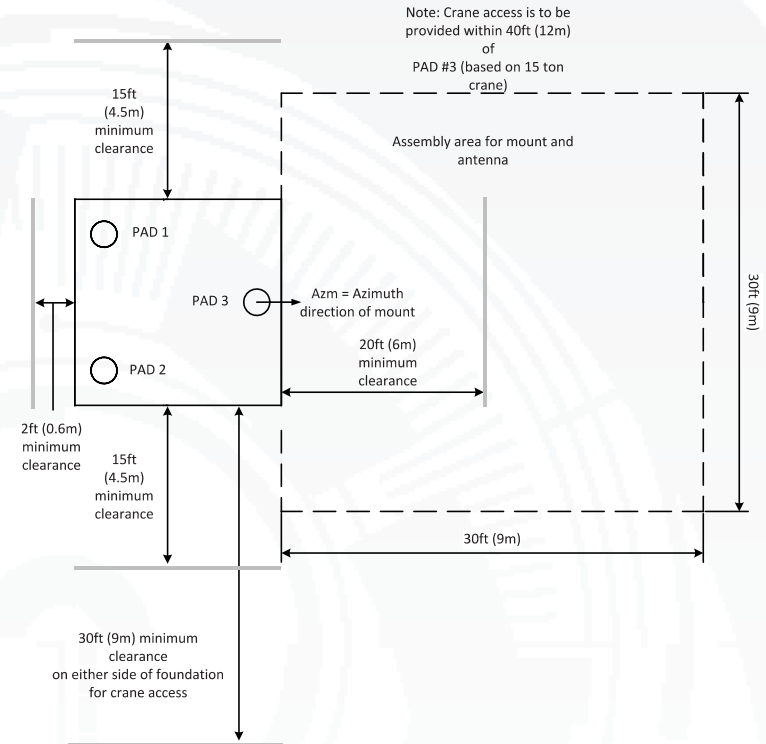

Soil Bearing Capacity,	2000 lb/ft ² (9770 kg/m ²)
Reinforcing Steel,	1308 lbs (593 kg)
Concrete Compressive Strength,	3000 psi (211 kg/cm ²)
Foundation Size:	(for specific standard soil and typical design)
Length	14 ft (4.27 m)
Width	14 ft (4.27 m)
Depth	1.67 ft (0.508 m)
Concrete Volume	12.1 yd ³ (9.25 m ³)

NOTE: Other typical foundation designs are available. Soil borings and foundation analysis should be performed by a qualified civil engineer.

5.6 Meter ESA

EARTH STATION ANTENNA

Motor Drive Speed Summary

	Variable	
Azimuth	0.05°/s	0.5°/s
Elevation	0.05°/s	0.5°/s
Polarization	1°/s	

Motorization

One motorization system is available for this antenna: the NGC tracking system that can support Steptrack, Smartrack and Ephemeris orbital tracking.

Motor Kit

Azimuth/Elevation Motor Kit	NGC-MK7
-----------------------------	---------

Polarization Drive Kit (DC Step Motors)

Standard Temperature	NGC-PK5DRA
----------------------	------------

Outdoor Unit Controller (Tracking)

Power 200 - 230 VAC, 3 Phase 50/60 Hz	NGC-ODU-208-5
Power 380 - 460 VAC, 3 Phase 50/60 Hz	NGC-ODU-380-5

Antenna controller, motorization and options are detailed in specific bulletins, please contact ASC Signal.

Antenna Configurations

Ku-Band Earth Station Antennas ITU Compliant

Motorizable Mount with Az/EI Jackscrews.	ES56-1
--	--------

Ku-Band Earth Station Antennas Eutelsat Compliant

Motorizable Mount with Az/EI Jackscrews. ¹	ES56-2
---	--------

K-Band Earth Station Antennas

Motorizable Mount with Az/EI Jackscrews. ¹	ES56KK-1
---	----------

¹ requires optical field alignment

Motorization and NGC Options

Indoor	
NGC-IDU	NGC Rack Mounted Antenna Controller W/LCD Touch Panel
NGC-001	NGC-IDU Analog Telephone Modem
NGC-002	NGC-IDU Spectrum Analyzer Card, Analog
NGC-003	NGC-IDU DVB Receiver Card
NGC-RTX-2	NGC IDU, L-Band Internal Beacon Receiver
NGC-006	NGC-IDU Emergency Stop Button
NGC-007	NGC-IDU 10 Mhz Reference Source
NGC-008	NGC-IDU Redundant Power Supply
NGC-009	NGC-IDU Rack Slides
NGC-101	NGC-IDU Step Tracking Software
NGC-102	NGC-IDU Smartrack Software
NGC-103	NGC-IDU Predictive Track Software
NGC-104	NGC-IDU Full Tracking Capability Software
NGC-106	NGC-IDU Remote Access Software Package
NGC-107	NGC-IDU Spectrum Analyzer Enhanced User Interface
NGC-108	Receive Pattern Test Tool
NGC-109	Redundancy Control Software
NGC-111	Sand/Dust Deviator Feature
NGC-115	Uplink Power Control Software Function
NGC-ULPC-INTFC	Uplink Power Control System Single Channel
NGC-ULPC-INTFC-2	Uplink Power Control System Dual Channel
NGC-119	NGC High Availability System Redundancy Software
Outdoor	
NGC-201	NGC ODU Low Temperature Kit (-40 C)
NGC-202	NGC ODU High Temperature Kit (+60 C)
NGC-205	NGC ODU AC Polarization Drive Interface
NGC-206	NGC Exterior Emergency Stop Button
NGC-207	Pre Movement Alert Warning Light And Annunciator
NGC-211	Dual Path NGC Redundancy
NGC-AESC	Environmental System Controller
RED11-x	Hub Mounted 1:1 LNA/LNB Redundancy Plate
RED12-x	Hub Mounted 1:2 LNA/LNB Redundancy Plate

Antenna controller, motorization and options are detailed in specific bulletins, please contact ASC Signal.

5.6 Meter ESA

Feed Matrix

Ku- BAND FEED SYSTEMS	PORT	LP	RX 10.95 - 12.75 GHz	RX 10.7 - 12.75 GHz	RX 10.7 - 11.7 GHz	RX 10.7 - 13.25 GHz	TX 12.75- 13.25 GHz	TX 13.0 - 14.5 GHz	TX 13.75- 14.5 GHz	TX 13.75- 14.8 GHz	TX 14.0 - 14.5 GHz
2LPKU-56	2	X				X				X	
2LPKU-56KK	2	X				X				X	
2LPKUM-56-W	X	X	X								X
2LPKUR-56-W	2	X		X							
4LPKU-56-1	4	X		X						X	
4LPKU-56-2	4	X			X		X			X	
4LPKU-56KK-1 ¹	4	X		X						X	
4LPKU-56KK-2 ¹	4	X			X		X			X	
4LPKU-56KK-4 ¹	4	X		X				X			

K- BAND FEED SYSTEMS	PORT	LP	RX 10.7 - 12.75 GHz	TX 17.3 - 18.4 GHz
2LPKK-56KK ²	2	X	X	X
4LPKK-56KK ²	4	X	X	X

¹ requires ES56-2 or ES56KK-1

² requires ES56KK-1

For redundant application, LNA support kits are available for each of the above feeds. Please contact ASC Signal.

5.6 Meter ESA

Antenna Options and Spares

Anchor Bolt and Template Kits Options

201630	Anchor Bolt Kit For 5.6 Meter Earth Station Antennas with Tripod Mounts
206505	Anchor Bolt Template for 5.6 Meter Earth Station Antennas with Tripod Mounts

Azimuth and Elevation Cross Axis Waveguide Options

XAPKK-56	K-Band cross Axis and Polarization Axis Waveguide Kit.
XAPKK-56-UPG	K-Band Cross Axis and Polarization Axis Waveguide Kit Upgrade. Upgrades XAPKK-56 for use with 4-port K-Band Feeds.
XAPKU-56	Ku-Band Cross Axis and Polarization Axis Waveguide Kit. Single run for 2-Port Ku-Band Feeds.
XAPKU-56-UPG	Ku-Band Cross Axis and Polarization Axis Waveguide Kit Upgrade. Upgrades XAPKU-56 for use with 4-Port Ku-Band Feeds. Provides Additional Waveguide Run.

Heating Options

FH5A	Ku and K-Band Feed Heater
WEC56R-208-100	Electric Hot Air De-Ice System, 208 VAC, 3 Phase
WEC56R-380-100	Electric Hot Air De-Ice System, 380 VAC, 3 Phase

Hub Equipment Options

EMRGYLT-115	Emergency Hub Light Kit, 115 VAC
EMRGYLT-230	Emergency Hub Light Kit, 230 VAC
FV65-115	Fan and Vent Kit, 115 VAC
FV65-220	Fan and Vent Kit, 230 VAC
HUBHTR-230	Antenna Hub Heater, 230 VAC
HUBLCNTR-115/240	Hub Power Center, 115/240 VAC
HUBLCNTR-230	Hub Power Center, 230 VAC
HUBLT-115	Hub Light Kit, 115 VAC
HUBLT-230	Hub Light Kit, 230 VAC

Safety Options

ANTGND-9	Foundation Installed Grounding Kit
LRK9	Lightning Rod Kit
MANPL7	Maintenance Platform and Ladder Kit
OBWRNLT-115	Obstruction Warning Light Kit, 115VAC
OBWRNLT-230	Obstruction Warning Light Kit, 230VAC

Other Options

201769	Elevation Handwheel Kit
201887	Azimuth Handwheel Kit
223711-56	Theodolite Alignment Kit ¹
ANGVERN-7	Manual Angle Indicator
209906-2	Lubrication and Maintenance Kit
BRNG-56-KUK	Guard, Feed Window Ku or K-band
FTST	Feed System Testing
TK-MAN-LG	Tool Kit, Large Manual Antennas
TK-MOT-LG	Tool Kit, Large Motorized Antennas

Environmental Systems Options

PDKU-56-208	Precipitation Deviator, 208 VAC, 3 Phase
PDKU-56-380	Precipitation Deviator, 380 VAC, 3 Phase

¹ required for ES56-2 and ES56KK-1

EARTH STATION ANTENNA