

4.5 Meter Tripod Mount ESA

Like all ASC Signal earth station antennas, the 4.5 Meter Earth Station Antenna provides high gain and exceptional pattern characteristics.

This antenna system is designed to address the stringent requirements of both the television broadcast industry and telecommunications network operators who demand unsurpassed flexibility and electrical performance in high-quality, cost-effective, and reliable packages.

The electrical performance and exceptional versatility provides the ability to configure the antenna in C-, X- and Ku-bands with the proper selection of feed and combiner systems. That versatility is provided at the time of initial purchase, as well as in the future, as your satellite communication requirements evolve.

This antenna system is used worldwide in broadcast applications and high density data, voice and communications networks. The ASC Signal 4.5 meter earth station antenna features a computer-optimized prime focus optics system and close-tolerance manufacturing techniques.

This combination provides extremely accurate surface contour resulting in exceptionally high gain and closely controlled pattern characteristics. ASC Signal earth station antennas provide maximum durability with minimal maintenance.



Features

- Self-aligning main reflector requires no field alignment
- Prime focus feed system optics and fully-shaped parabolic main reflector provide excellent pattern characteristics
- 3 year warranty on all structural components
- C, X, Ku Band Capabilities

4.5 Meter Tripod Mount ESA

EARTH STATION ANTENNA

Design Standards

Reflector	Aluminum painted with highly diffusive white paint
Ground Mount	Hot-dipped galvanized steel, per ASTM-A123 for structural steel.
Hardware	Sizes ≤ 3/8 in (9.5mm), stainless steel, passivated per MIL-F-14072-E300 Sizes ≥ 3/8 in (9.5mm), hot-dipped galvanized stainless steel, passivated per ASTM-A123

Environmental Performances

Operating Temperature	-40° to 52°C (-40° to 125°F)
Seismic (Earthquake)	1 G Vertical and Horizontal acceleration. Equivalent to a Richter Magnitude 8.3, and Grade 11 on the modified Mercalli Scale
Operational Winds	45 mph (72 km/h) Gusts to 65 mph (105 km/h)
Survival Winds	125 mph (200 km/h) in any position of operation
Rain	4 in (102 mm) per hour
Solar Radiation	360 BTU/hr/ft ² (1135 Watts/m ²)
Relative Humidity	100%
Shock and Vibration	As encountered by commercial Air, Rail and Truck shipment.
Atmospheric Conditions	As encountered by Moderately Corrosive Coastal and Industrial Areas.

Antenna Configurations

C, X, Ku Band Earth Station Antennas	
Manual Tripod Mount Receive Only.	ES45T-R-1
Manual Tripod Mount Transmit/Receive	ES45T-T-1

Mechanical Performances

The 4.5m Antenna mechanical general specifications and performances are listed in below table. Additional information, dimensions and layout may be provided by ASC Signal on a case-by-case basis.

Optics Type	Prime Focus
Reflector Material	Precision-Formed Aluminum
Reflector Segments	6
Mount Type	Az over El, Manual Tripod Mount

Antenna Pointing Range, Coarse/(Continuous)

Elevation:	2-90° (2-60° std, 33-90° with option 49713-2)
Azimuth:	180° (120°)
Polarization	180° (180°)

Shipping Information

Packing Options

Standard Commercial Domestic Pack	Included
Ocean Export Pack - For non-containerized, packed for seal against salt water spray	OCEANSHIP-SML
Air Export Pack - For freighter aircraft shipments. Lower deck AirPack requires specialized bids	AIR EXPORT PACK-SML
Container Packaging	CNTPCK-SML

Required Shipping Container

Standard 20 ft land/sea container	Quantity 1
-----------------------------------	------------

Shipping container information is given for basic configuration and may vary depending on the selected options, please contact ASC Signal for specific container loading plan.

4.5 Meter Tripod Mount ESA

Dimensional Drawings

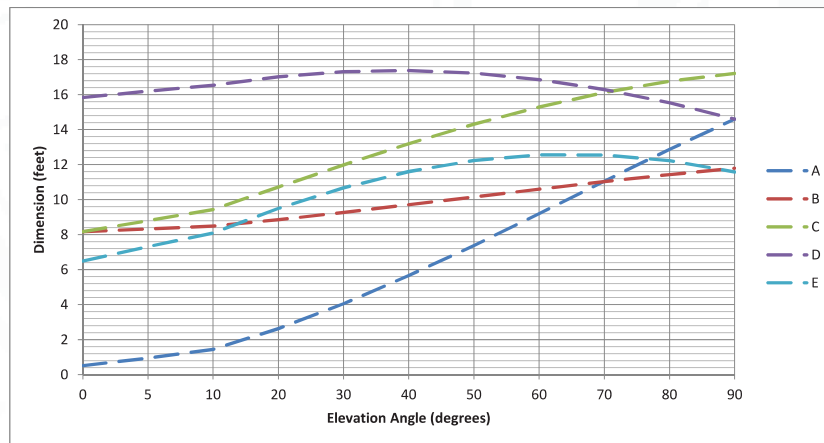
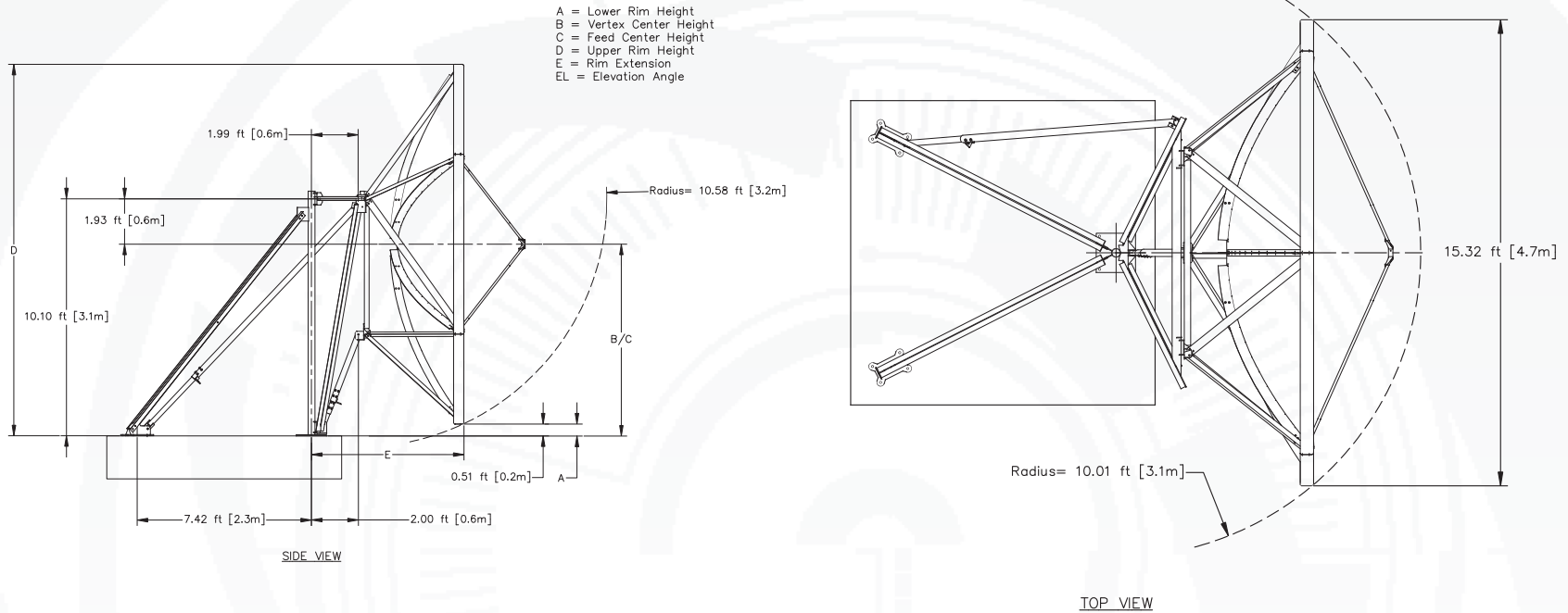

EARTH STATION ANTENNA

4.5 Meter Tripod Mount ESA

Foundation, Typical Slab

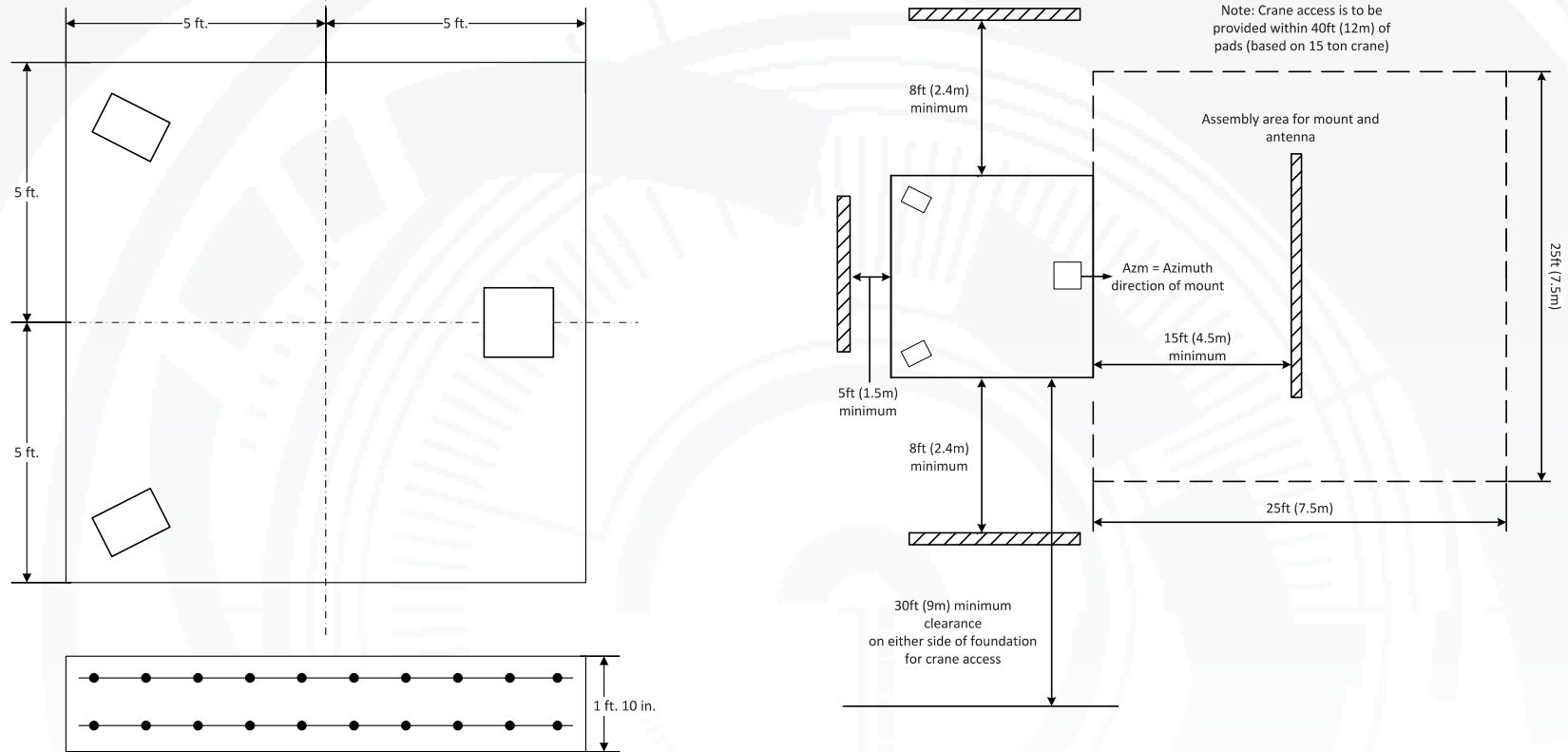

Foundation information are provided in bulletin 37690B, please contact ASC Signal.

Soil Bearing Capacity,	2000 lb/ft ² (9770 kg/m ²)
Reinforcing Steel,	Lbs (Kilograms)
Concrete Compressive Strength,	3000 psi (211 kg/cm ²)
Foundation Size:	(for specific standard soil and typical design)
Length	10 ft(3.05m)
Width	10 ft(3.05m)
Depth	1 ft 10 in(0.559 m)
Concrete Volume	6.8 yd ³ (5.2 m ³)

NOTE: Other typical foundation designs are available. Soil borings and foundation analysis should be performed by a qualified civil engineer.

4.5 Meter Tripod Mount ESA

Feed Matrix

C- BAND FEED SYSTEMS	PORT	CP	LP	CO	RX 3.4 - 4.2 GHz	RX 3.625 - 4.2 GHz	RX 4.5 - 4.8 GHz	TX 5.850 - 6.425 GHz	TX 5.850 - 6.725 GHz	TX 6.725 - 7.025 GHz
2CLPC-45	2			X		X		X		
2CPC-45-109	2	X	X			X		X		
2CPCR-45-109	2	X				X				
2CPWCR-45-120	2	X			X					
2LPC-45	2		X			X		X		
2LPCR-45	2		X			X				
2LPWC-45	2		X		X				X	
2LPWCR-45	2		X		X					
2LPUC-45	2		X				X			X
4CPNC-45-206	4	X				X		X		
4LPCM-45	4		X			X		X		

X- BAND FEED SYSTEMS	PORT	CP	RX 7.25 - 7.75 GHz	TX 7.9 - 8.4 GHz
2CPX-45	2	X	X	X

Ku- BAND FEED SYSTEMS	PORT	LP	RX 10.95- 12.75 GHz	RX 10.7 - 13.25 GHz	TX 13.75- 14.8 GHz
2LPKR-45-W	2	X	X		
2LPKUNV-45	2	X		X	X

C/Ku- BAND FEED SYSTEMS	PORT	KU LP	C LP	C CP	RX 3.625 - 4.2 GHz	RX 10.95- 12.75 GHz
4CPCLKR-45-W	4	X		X	X	X
4LPCKR-45-W	4	X	X		X	X

EARTH STATION ANTENNA

4.5 Meter Tripod Mount ESA

Antenna Options and Spares

Anchor Bolt and Template Kits Option

47429A	Anchor Bolt Kit for 4.5 Meter Tripod Earth Station
300534	Anchor Bolt Template for 4.5 Meter Tripod Earth Station

Azimuth and Elevation Cross Axis Waveguide Options

1XAC-45	C-Band Cross Axis Waveguide Kit, 2-Port.
1XPC-45	C-Band Polarization Waveguide Kit, 2-Port.
1XPK-45	Ku-Band Polarization Waveguide Kit, 2-Port.
2XAC-45	C-Band Cross Axis Waveguide Kit, 4-Port.
2XPC-45	C-Band Polarization Waveguide Kit, 4-Port.
2XPK-45	Ku-Band Polarization Waveguide Kit, 4-Port.

Heating Options

FR45A	Full-Reflector Heater Pads
-------	----------------------------

Safety Options

ANTGND-5	Foundation Installed Grounding Kit
LTK5	Lightning Rod Kit
OBWRNLT-115	Obstruction Warning Light Kit, 115VAC
OBWRNLT-230	Obstruction Warning Light Kit, 230VAC

Other Options

49713-2	Elevation Strut Extension 4.5 Meter Series ES45T-(*) Tripod Mount Earth Station Antennas 33-90 Degree Elevation Range
7585441	Kit,Feed Constraint,4.5M
FTST	Feed System Testing
TK-MAN-SML	Tool Kit, Small Manual Antennas

EARTH STATION ANTENNA

Request A Quote