

500W AC/DC OUTDOOR / Indoor Power Supply

Features:

- ◆ Based on GaN Technology
- ◆ Highly Efficient up to 92%
- ◆ Integrated M&C for BUC
- ◆ Est. MTBF + 15 Years
- ◆ Built-in Power Factor Correction
- ◆ Built-in AC/DC Voltage & Current Protection
- ◆ High Temperature Operation
- ◆ Compact Design in a Robust Outdoor Housing
- ◆ Fanless - Conduction Cooling
- ◆ 3 Year Warranty

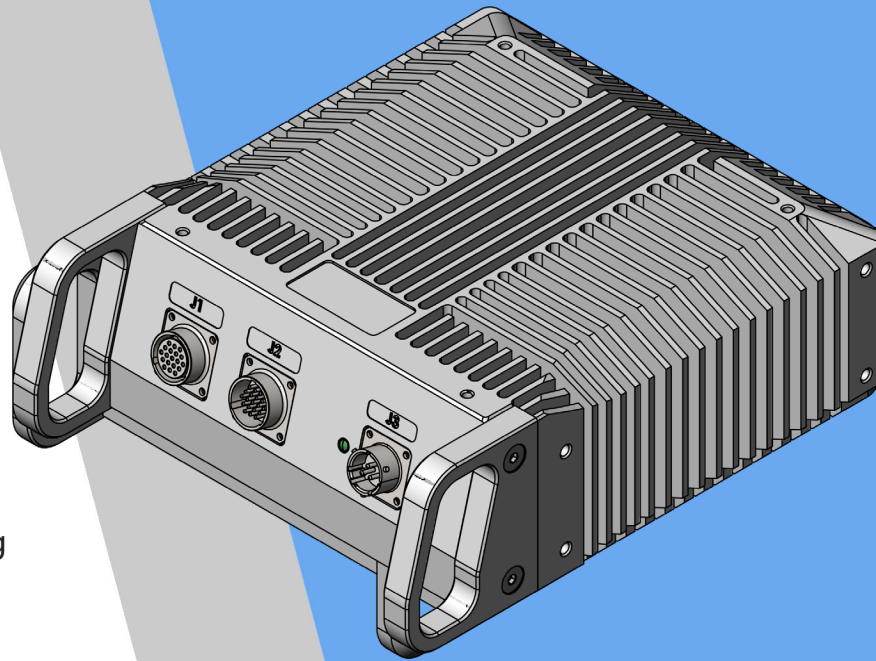

[Request A Quote](#)

Design Overview:

The flagship efficient, compact and robust 500W Amkom AC/DC power supply with built-in power factor corrector (PFC) and integrated BUC Monitor and Control was designed specifically for those in need of reliable power at the antenna with efficiency, size and weight in mind.

Each model has its own benefits and options, for more information please contact our support team: support@amkominc.com

PART NUMBERING SYSTEM

ACDC - Conversion Type
UNI - Universal Brand BUC
AM- AMKOM BUC Series Type/Use
AUX- Auxiliary Power option
500- Watts
300- Watts
24/28/48 - VDC Output
C - Customized Option

TECHNICAL SPECIFICATIONS - Preliminary

AC Input Voltage	85 - 265 VAC, 47-63 Hz
AC Current	3.3 / 1.7 A (Max Ratings)
Efficiency	92 %
Power Factor	0.95 minimum (Vin=230VAC, Io > 80%, Tc=25°C, meets EN61000-3-2)
Output Voltage	24, 28, 48 VDC
Output Current	18A 500W, 10.5A at 48VDC
Operating Temperature Range	- 40° C to + 60°C
Storage Temperature Range	- 60°C to + 85°C
Humidity	100% Condensing, IP67 Compliant
M&C (NO DC) Pass through to User PC	MIL-STD Connector PT02E-14-19P (027) RoHS Compliant
M&C + DC Pass Through to BUC	MIL-STD Connector PT02E-14-19P (027) RoHS Compliant
Dimensions	8.82" x 10.83" x 3.35" (224mm x 275mm x 85mm)

MECHANICAL DRAWING

