

**LNBK, Ku-Band
1:2 Redundant
LNB Plate Assembly**



RCP2-1200 Redundant Controller

DESCRIPTION

The LNB Series Low Noise Block Down Converter Systems provide the ultimate system reliability by providing complete back up operation. The LNB series redundant system utilizes the RCP2-1100 redundant controller to provide fault detection and switchover in the event of a Low Noise Block Down Converter failure.

Teledyne Paradise Datacom can provide dual 1:1 redundant systems, 1:2 redundant systems, and a wide variety of custom systems. The outdoor equipment consists of the switch plate assembly and the Low Noise Block Down Converters and associated components. The controller provides complete visual indication of switch position, fault detection, and system status.

FEATURES

- Reliable, weather sealed outdoor equipment
- Manual or Automatic Switchover on fault
- 1 Rack Unit high indoor controller
- 1:1, 1:2 or Dual 1:1 system configurations
- Standard 100 ft. (30m) control cable
- Universal input AC power supply on controller
- LNB bias supplied by indoor controller

OPTIONS

- TX Reject Filters
- Offline Input Coupler
- Internal or External reference
- Offline & Test Ports
- Custom frequency bands
- Modified LNBs to add alarm function

SPECIFICATIONS

- IF Output Frequency:
950-1750 MHz C-Band;
950-1450 MHz X-Band;
950-1450 MHz Ku-Band
- Conversion Gain: 55-70 dB
- Input/Output VSWR: 2.2:1
- Spurious: -50 dBc
- Input Power (+15 to +24 VDC):
350 mA max C-Band;
200 mA max Ku-Band
- Output Power (P1dB):
+5 dBm C-Band;
+5 dBm X-Band;
+5 dBm Ku-Band

[Request A Quote](#)

Typical System Block Diagrams

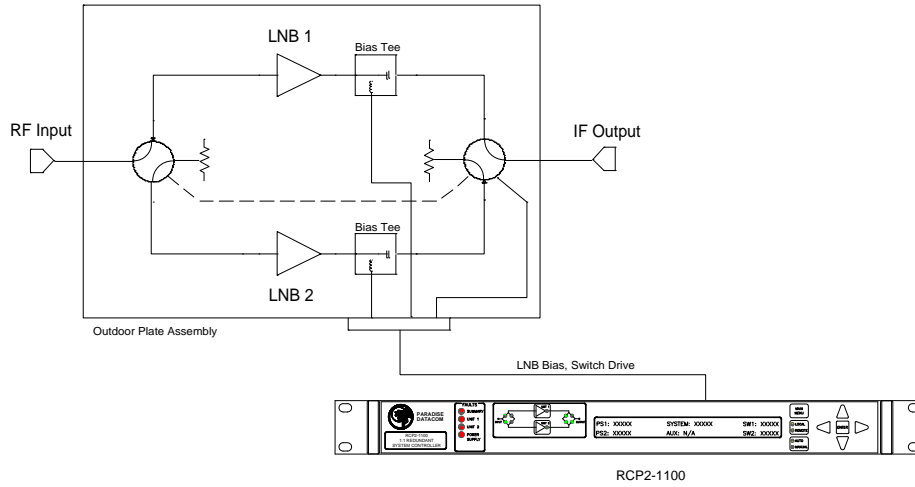

Standard 1:1 Redundant System, with output switching

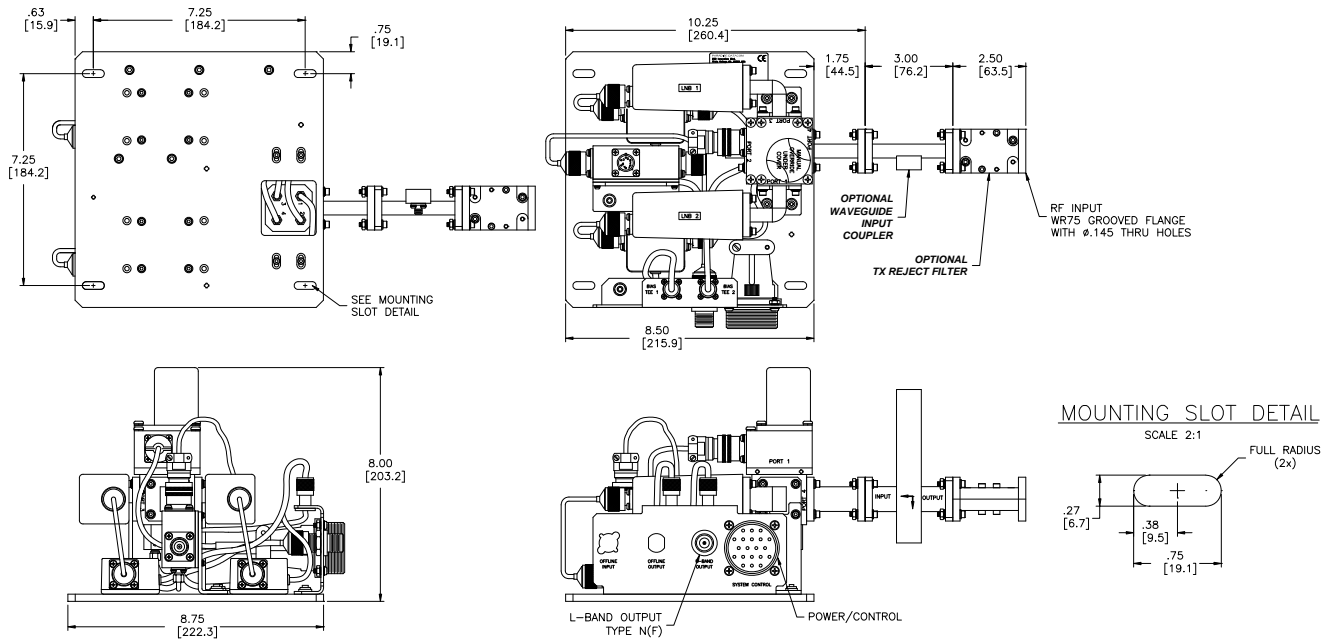

Ku-Band 1:1 Redundant LNB Plate Assembly

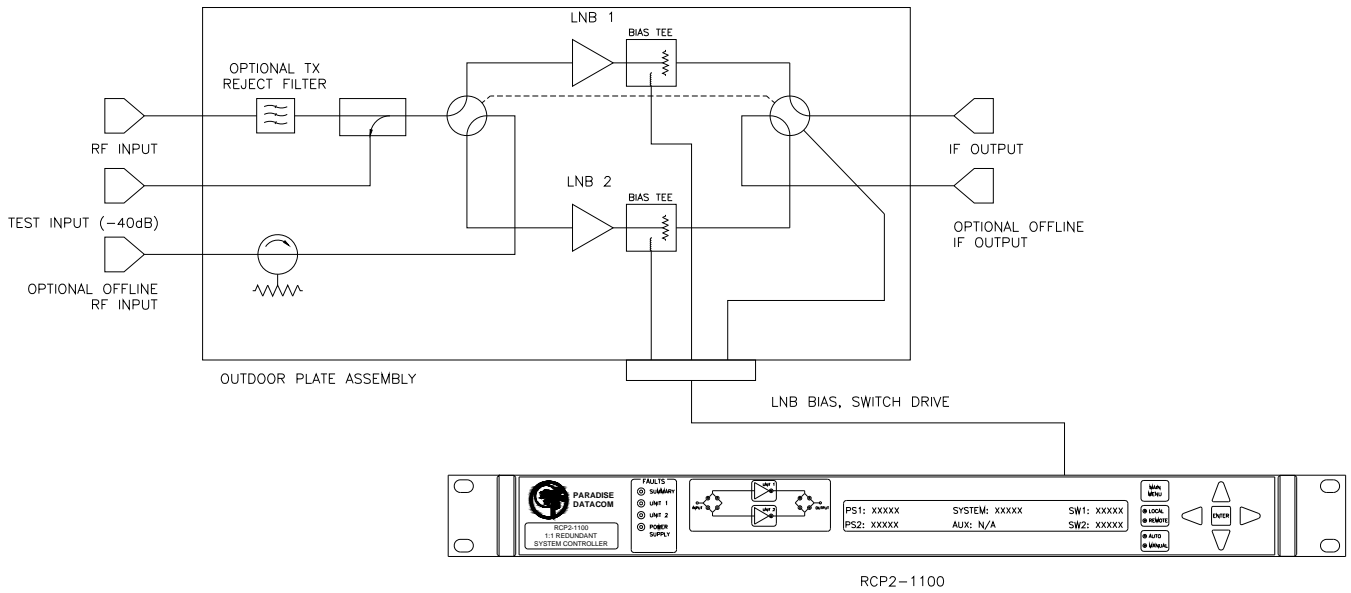

1:1 LNB System with optional test input port, offline ports, TX reject filter, and output switching

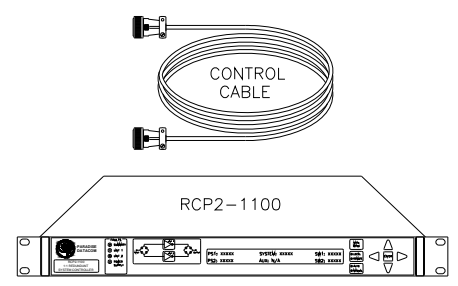
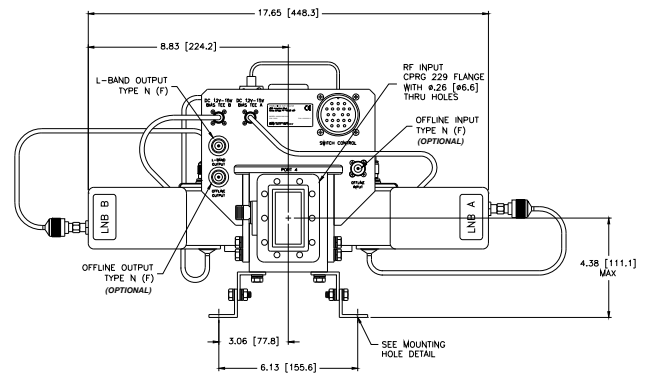
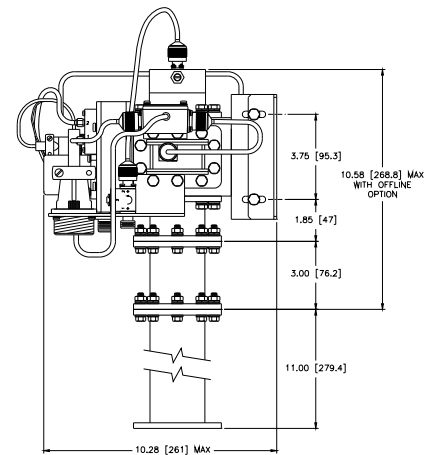
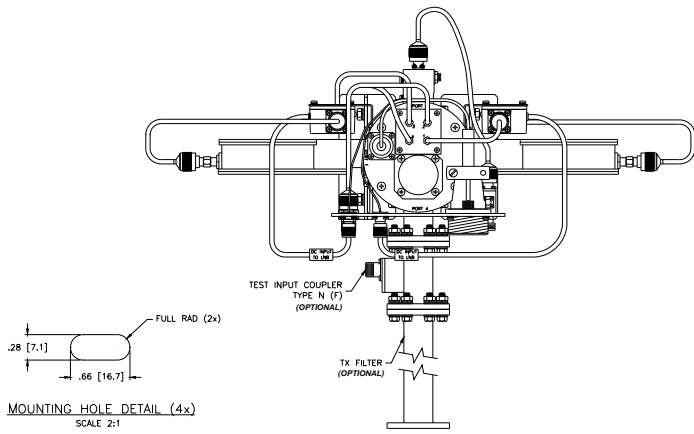

202969P1B.DWG

C-Band 1:1 Redundant LNB System with RCP2-1100 and control cable

Typical System Block Diagrams

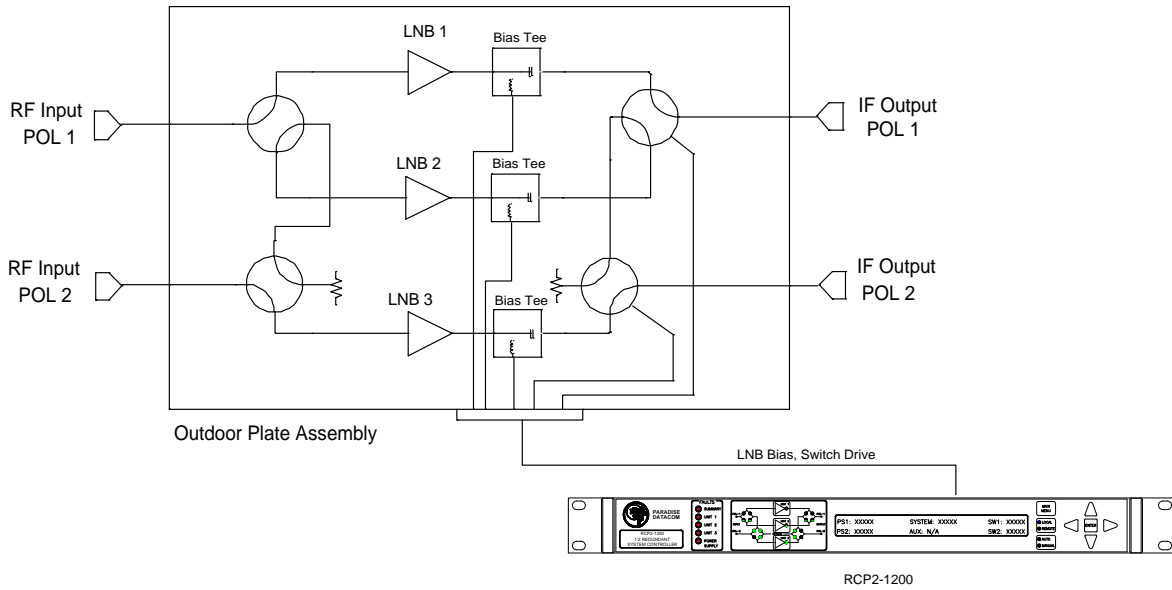

Standard 1:2 Redundant System, shown with output switching

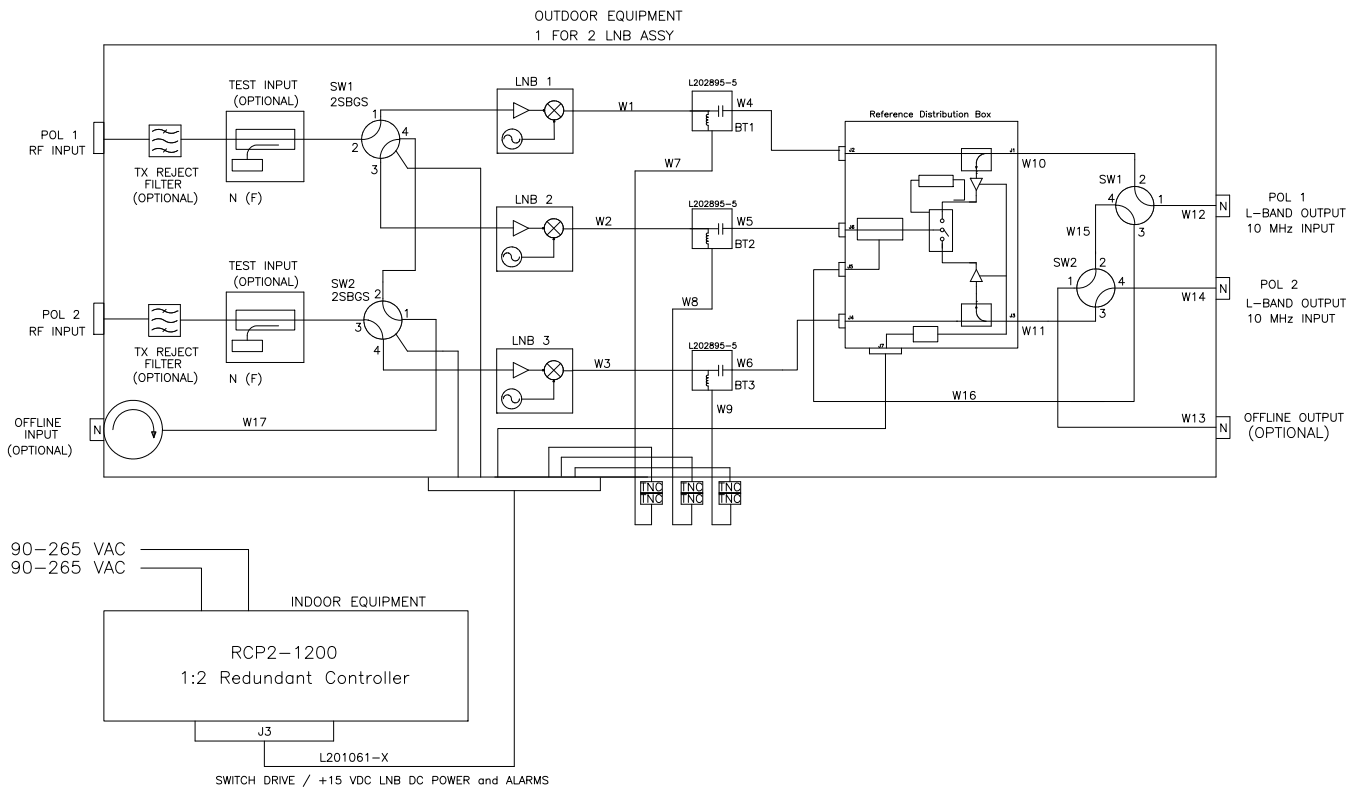

1:2 Redundant System, shown with RCP2-1200 controller, reference distribution box, optional Offline Input & Output, optional Tx Reject Filter and optional Test Input

Typical Outline Drawing

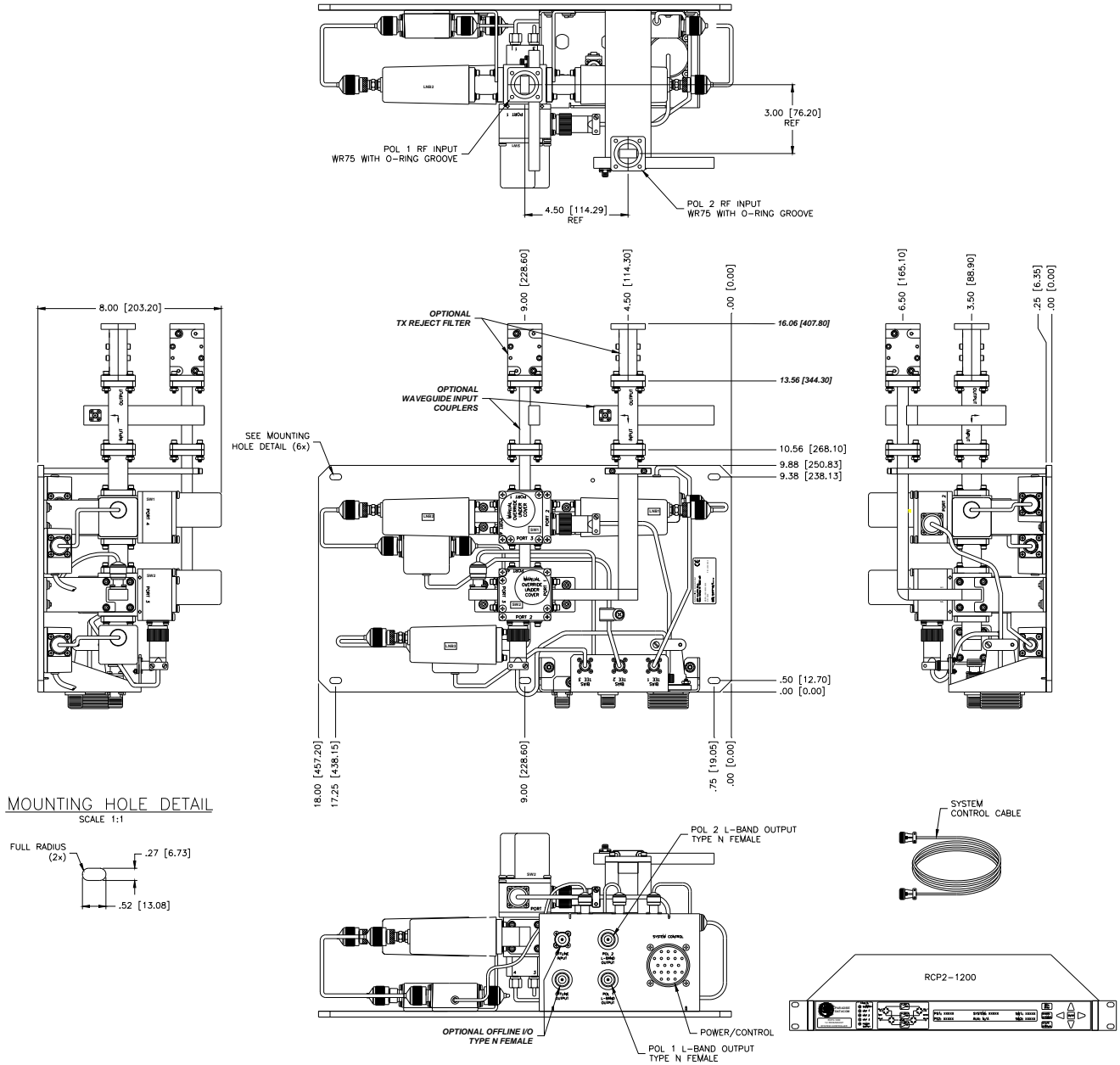

Ku-Band 1:2 Redundant LNB with RCP2-1200 and control cable

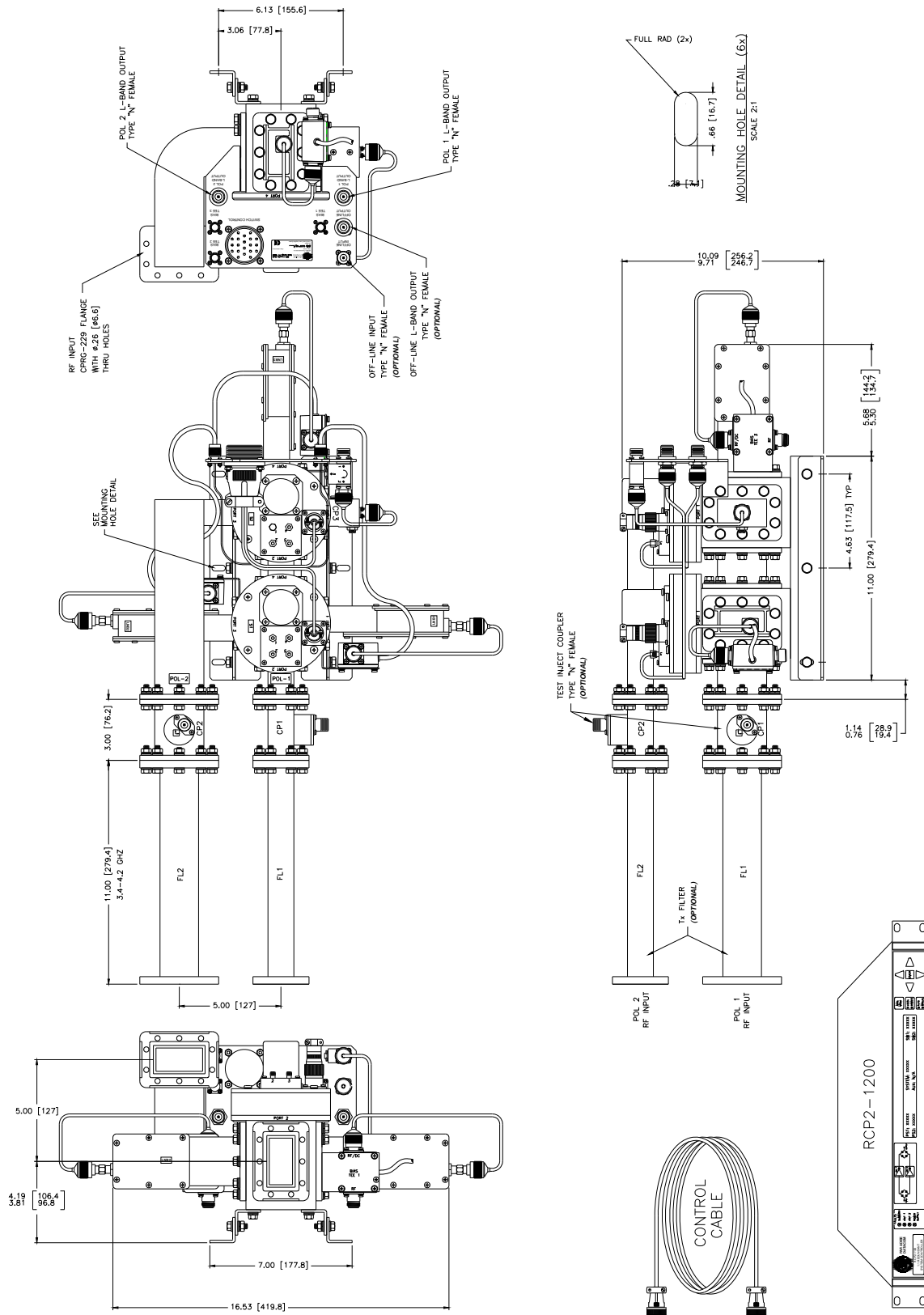

C-Band 1:2 Redundant LNB System with RCP2-1200 and control cable

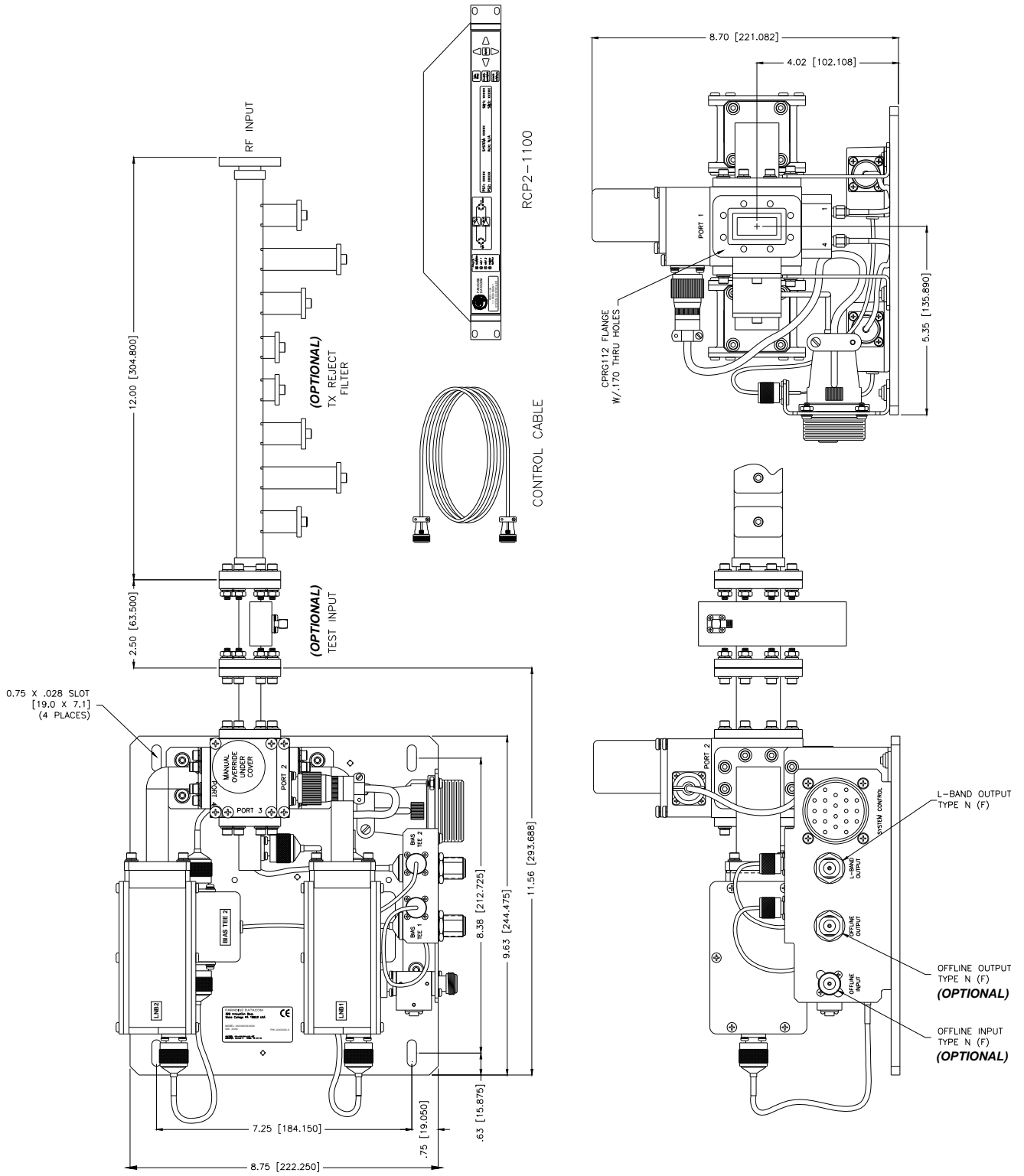

X-Band 1:1 Redundant LNB with RCP2-1100 and control cable

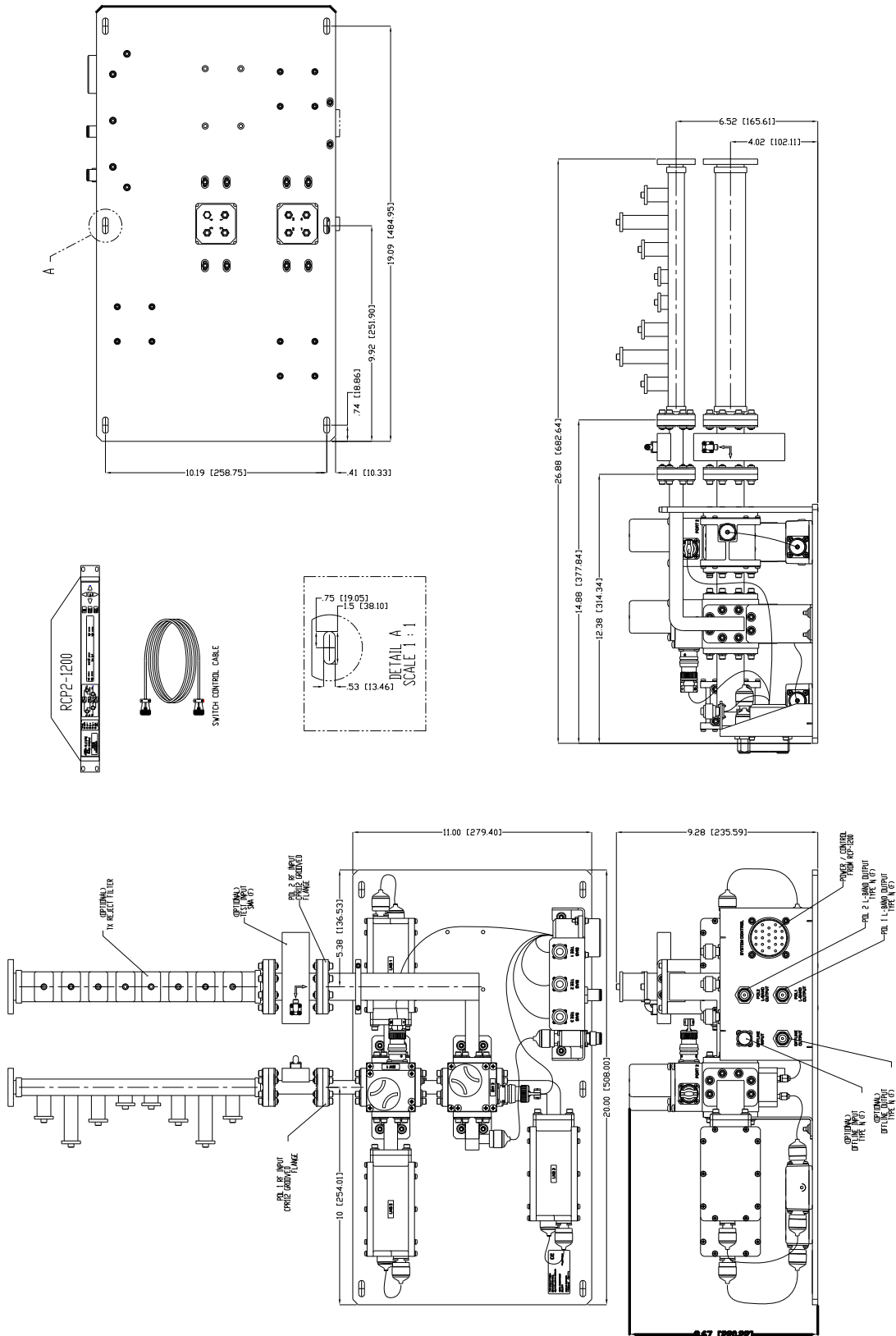

X-Band 1:2 Redundant LNB System with RCP2-1200 and control cable

Typical LNB Specifications

PARAMETER	C-Band	X-Band	Ku-Band	Ka-Band
IF Output Frequency	950-1750 MHz	950-1450 MHz	950-1450 MHz	950-1950 MHz
Input Waveguide/Flange	CPR-229 Grooved	WR-112 Grooved	WR-75 Grooved	WR-42 Grooved
Output Connector Internal Reference LNB External Reference LNB	Type N female Type N female	Type N female Type N female	Type N female Type N female	Type N female Type N female
RX Noise Figure (typical)	25 K	0.7 dB	0.7 dB	1.4 dB
LNB Conversion Gain, 60dB typical	55-70 dB	55-70 dB	55-70 dB	56 dB
Gain Flatness (any 40 MHz band)	± 0.5 dB	± 0.55 dB	± 1.5 dB pp	±0.5 dB
Output Power, P _{1dB}	+5 dBm	+5 dBm	+5 dBm	+5 dBm
Input / Output VSWR	2.2:1	2.0:1	2.5:1 / 2.2:1	2.2:1 / 2.0:1
Output Third Order Intercept	+15 dBm	+15 dBm	+15 dBm	+15 dBm
Image Rejection	40 dB	45 dB	50 dB	45 dB minimum 60 dB typical
Group Delay Variation (any 40 MHz band)	< 10 ns	< 30 ns	< 30 ns	< 1 ns
Spurious	-50 dBc	-50 dBc	-50 dBc	-50 dBc
Typical Phase Noise	100 Hz	-60 dBc /Hz	-60 dBc /Hz	-60 dBc/Hz
	1 KHz	-75 dBc/Hz	-75 dBc /Hz	-65 dBc/Hz
	10 KHz	-80 dBc/Hz	-85 dBc /Hz	-75 dBc/Hz
	100 KHz	-90 dBc/Hz	-95 dBc /Hz	-95 dBc/Hz
Input Power, +15 to +24 VDC	350 mA max	230 mA max	200 mA max	300 mA max

OEM LNB Operation

Teledyne Paradise Datacom LNB systems are configured with OEM LNBs which do not have fault detection alarm circuitry.

For full, automatic redundancy switching, an LNB alarm is required. Teledyne Paradise Datacom can modify OEM LNBs to add fault detection alarm circuitry. Make sure to select the “XA” option of the configurator.

If automatic switching is not required, the OEM LNBs may be used without modification.

In either case, the LNBs are powered by +15 VDC current through the control cable, provided via the RCP redundant controller (if ordered with the system). The user may program the controller to report a fault on modified LNBs based on a change in the bias current.



OEM C-Band LNB

Model Number Configuration

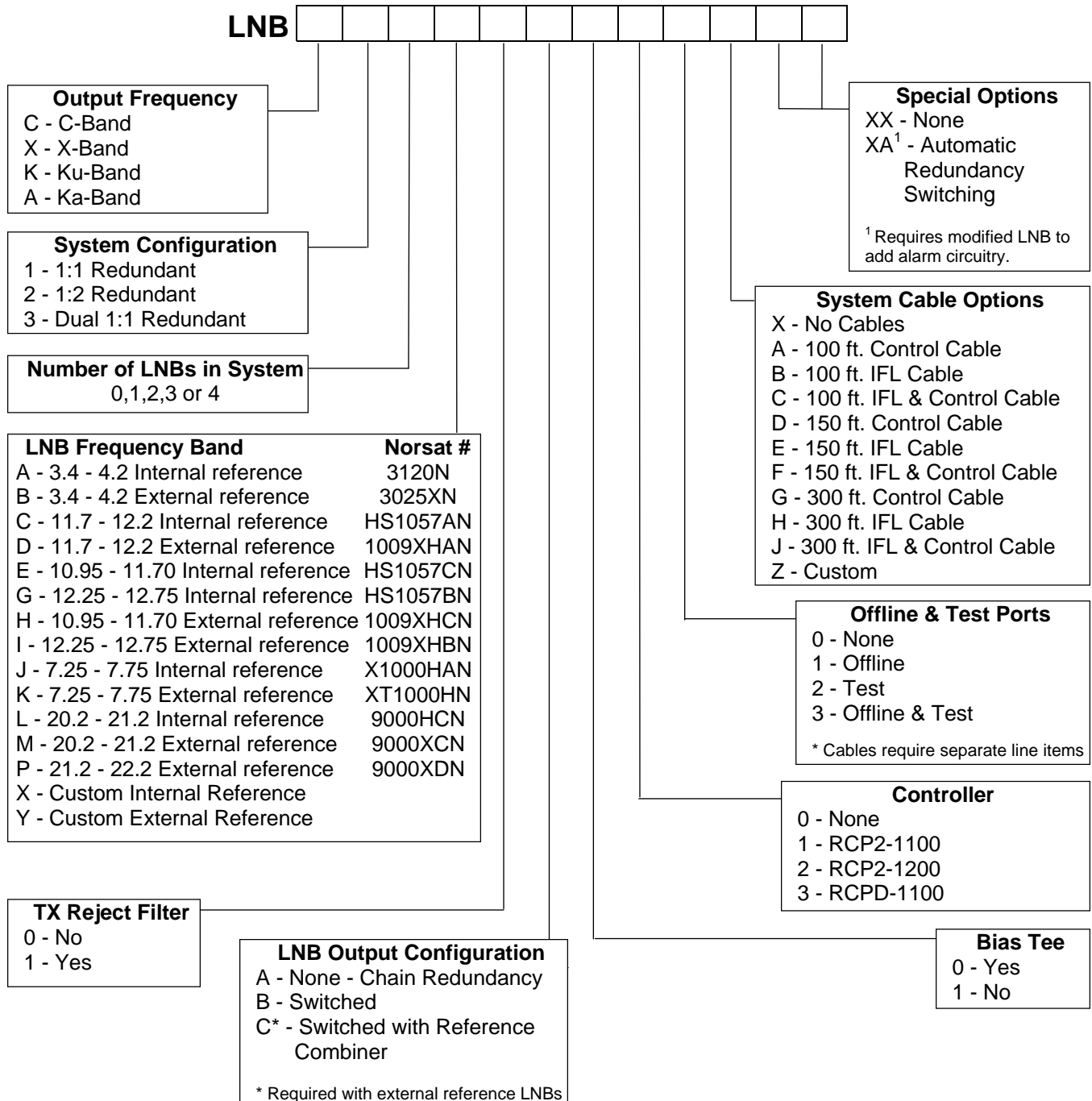

Example: A 1:1 C-Band chain redundant system with two internally referenced LNBs, optional TX reject filter, bias tees, with a RCP2-1100 controller and 100 ft. control cable; the part number is: LNBC12A1A010AXX

Specifications listed in this document are subject to change without notice.

X-Band products may be subject to ITAR restrictions and should not be exported from the U.S. without obtaining proper licensing from the appropriate government agencies.