

2016-1327 Downconverter, 1.3 - 2.7 GHz

The 2016-1327 Downconverter converts 1300 to 2700 MHz to 70 MHz in 1 MHz steps with low group delay and flat frequency response. Synthesized local oscillators (LO) provide frequency selection. Multi-function switches select the input frequency, gain, and other parameters. Front panel LEDs provide indication of DC power, PLL alarm or Remote operation. Gain is adjustable manually (MGC) over a 0 to 30 dB range. The frequency and gain are remotely selectable. Parameter selection and frequency and gain settings appear on the LCD display. Connectors are **BNC female for the RF, IF** and optional external 10 MHz reference input and output (option -E). Tables below show connector and other options. The 2016-1327 is powered by a 100-240 \pm 10% VAC, 47-63 Hz power supply, and is contained in a 1 3/4" X 19" X 16" rack mount chassis.

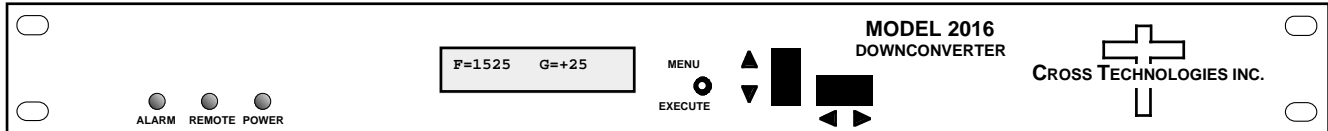

Front Panel

EQUIPMENT SPECIFICATIONS*

Input Characteristics

Impedance/Return Loss	50Ω/10 dB
Frequency	1300 to 2700 MHz
Noise Figure, Max.	15 dB max. gain
Input Level range	-50 to -20 dBm
Input 1 dB compression	-15 dBm

Output Characteristics

Impedance/Return Loss	75 Ω / 18 dB
Frequency	70 \pm 18 MHz
Output Level/max linear	-20 / -10 dBm
Output 1 dB compression	-5 dBm

Channel Characteristics

Gain range (adjustable)	0.0 to +30.0 dB (1dB steps)
Image Rejection	> 50 dB, min.
Frequency Response	\pm2.0 dB, 1300 to 2700 MHz ; \pm 0.75 dB, 36 MHz BW
Spurious Response	< -50 dBc, in band
Group Delay, max	0.015 ns/MHz² parabolic; 0.05 ns/MHz linear; 1 ns ripple
Frequency Sense	Non-inverting

Synthesizer Characteristics

Frequency Accuracy	\pm 1.0 ppm max over temp (\pm 0.02 ppm optional)
Frequency Step	1.0 MHz (125 kHz steps is OPTION X)
10 MHz Level (In or Out)	+3 dBm, \pm 3 dB, 75 ohms (option E)

Phase Noise @ Freq	100Hz	1kHz	10kHz	100kHz	1MHz
dBC/Hz	-70	-70	-80	-90	-100

Controls, Indicators

Frequency Selection	direct readout LCD; manual or remote selection
Gain Selection	direct readout LCD; manual or remote selection
Power; Alarm; Remote	Green LED; Red LED; Yellow LED
Remote	RS232C, 9600 baud (RS485, option Q)

Other

RF Connector	BNC, 50 ohm (female)
IF, 10 MHz Connectors	BNC (female) Option E
Alarm/Remote Connector	DB9 (female) - NO or NC contact closure on Alarm
Size	19 inch, 1RU standard chassis 1.75" high X 16.0" deep
Power	100-240 \pm 10% VAC, 47-63 Hz, 45 watts max.

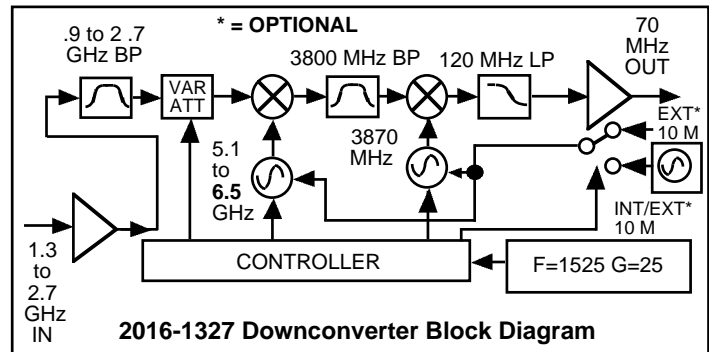

2016-1327 Downconverter Block Diagram

Available Options

- E - External 10 MHz ref input & output
- H - High Stability (\pm 0.01ppm) Internal Ref
- Q - RS485 Remote Interface
- T - Temperature Sensor
- W8 - Ethernet M&C Remote Interface
- W18 - Ethernet Interface w/SNMP
- X - 125 kHz Frequency Step Size

Connectors/Impedance

- STD - 50 Ω BNC (RF), 75 Ω BNC (IF)**
- D - 50 Ω BNC (RF), 50 Ω BNC (IF)
- M - 50 Ω Type N (RF), 50 Ω BNC (IF)
- N - 50 Ω Type N (RF), 75 Ω BNC (IF)
- S - 50 Ω SMA (RF), 50 Ω BNC (IF)

10°C to 40°C; Specifications subject to change without notice

