

DT-4500 Series Down Converters

Converters



Overview

Our Down Converters are the ultimate in high performance and cost effective Ku-Band frequency conversion. These can be used for SCPC, DAMA, and TDMA, as well as full transponder HDTV and analog TV. Spectral purity and stability characteristics fully meet or exceed the requirements of all domestic, international, and regional commercial satellite networks.

Available Models

Band	Down Converter
C	DT-4503/X
Ku	DT-451X
X	DT-4572

High Gain

Our Down Converters have +20 dBm minimum output level at the 1 dB compression point and 45 dB of gain as a standard. This capability permits longer cable runs to the modem rack or compensates for elaborate splitting networks without adding expensive options such as external line amplifiers.

Low Phase Noise

The phase noise performance exceeds the Intelsat phase noise mask for IBS and IDR services by more than 9 dB. This allows phase dependent demodulators to perform better. The close-in phase noise is very low, making the converter ideal for low bit rate digital circuits such as those used in DAMA hub earth stations.

Remote Control

The remote control interface is selectable between EIA-232 and EIA-485, as well as full Ethernet including Telnet, SNMP and pre-loaded HTML GUI. All configuration control, status retrieval, and adjustments are available as simple ASCII commands through the serial interface or through the front panel menu. As a cost option, the remote control command structure can be customized in order to accommodate existing network control software.

Detachable RF/IF Connector Module

Each converter is equipped with a detachable module that establishes input and output connections for the RF and IF paths. The module inserts into a rear compartment of the converter, and requires no additional outside space. The module includes SMA connectors for the RF path and BNC connectors at 50 or 75 Ω for the IF path.

Daisy Chain Redundancy Switching

The converters use our patented "Daisy Chain" integrated switching technology. The Daisy Chain design removes the relays associated with a centralized protection switch tray and distributes them across the individual converters. Daisy Chain technology successfully eliminates a central switching chassis, two power supplies, a microprocessor, and several long, costly cables. Widely accepted in the industry, Comtech EF Data's Daisy Chain provides both pricing and marketing advantages.

Minimum Rack Space

Due to its small rack height (1.75 inches) and the elimination of the space penalty paid for a separate 1+N switch chassis, the Down Converter and the Daisy Chain switch architecture provide the most compact and cost effective converter subsystem available. The units are ideal for the construction of transportable systems such as "flyaways," and high capacity earth stations where space utilization and economy are prime considerations.

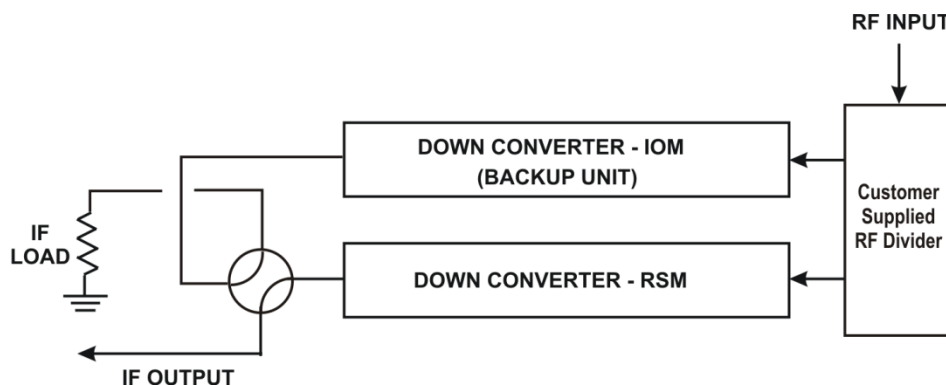

1:1 Redundant Configuration Diagram – Single Source IF Output RSM-XX Installed

Specifications

Available Models	Frequency Range
DT-4503	3625 to 4200 MHz
DT-4503/C	3400 to 4200 MHz
DT-4503//D	3400 to 3700 MHz
DT-4503/E	4500 to 4800 MHz
DT-4510	10.95 to 11.70 GHz
DT-4510/D	10.70 to 11.70 GHz
DT-4511	11.70 to 12.20 GHz
DT-4512	12.20 to 12.75 GHz
DT-4512/E	12.50 to 12.80 GHz
DT-4513	10.95 to 12.75 GHz
DT-4513/E	10.70 to 12.75 GHz
DT-4572	7250 to 7750 MHz

Conversion	Dual, No Inversion
Step Size	125 KHz standard, 1 kHz optional
Preset Channels	32 Frequencies and Gains
Stability Over Time	$\pm 1 \times 10^{-9}$ /Day
Stability Over Temperature	$\pm 1 \times 10^{-8}$ 0 to 50°C

RF Input

Input Level	-45 dBm Typical
Return Loss	20 dB Minimum with I/O Module
Impedance	50 Ω
Noise Figure	11 dB Maximum at 0 dB Attenuation

IF Output

Level	+20 dBm at 1 dB Compression
Range	52 to 88 or 104 to 176 MHz Optional 50 to 90 MHz or 100 to 180 MHz (Contact factory with specific requirements)
Non-Carrier Spurious	-80 dBm
Carrier Spurious	-65 dBc at 0 dBm Output
Intermodulation	-60 dBc at 0 dBm Output SCL
Impedance	50 or 75 Ω
Return Loss	23 dB Minimum

Transfer

Gain	45 dB \pm 2 dB
Attenuation Adjust	0 to 20 in 0.25 dB Steps 0.1 dB Steps Optional
Gain Stability	\pm 0.25 dB/Day
Ripple	\pm 0.25 dB (\pm 18 MHz) Optional \pm 20 MHz 0.75 dB (\pm 36 MHz) Optional \pm 40 MHz (Contact factory with specific requirements)
Slope	0.05 dB/MHz
Image Rejection	-80 dB In-band
AM to PM	0.1°/dB for Output up to -5 dBm
IF Bandwidth	36 or 72 MHz, Optional 40 or 80 MHz (Contact factory with specific requirements)

External Reference

Input, either 5 or 10 MHz Option @ +3 dBm
Optional 10 MHz Rear Panel Reference Output

Group Delay

Linear	0.03 ns/MHz
Parabolic	0.01 ns/MHz ²
Ripple	1.0 ns Peak-to-Peak

Phase Noise

	Limit (dBc/Hz)		Typical (dBc/Hz)	
	DT-4503/X		DT-4503/X	
100 Hz	-80		-83	
1 KHz	-89		-92	
10 KHz	-95		-97	
100 KHz	-105		-109	
1 MHz	-120		-124	

	Limit (dBc/Hz)		Typical (dBc/Hz)	
	DT-451X	DT-4513, DT-4513/E	DT-451X	DT-4513, DT-4513/E
100 Hz	-72	-66	-79	-69
1 KHz	-79	-76	-82	-79
10 KHz	-89	-86	-92	-89
100 KHz	-98	-96	-101	-99
1 MHz	-110	-106	-114	-109

	Limit (dBc/Hz)		Typical (dBc/Hz)	
	DT-4572/DT-4503/E		DT-4572/DT-4503E	
100 Hz	-69		-79	
1 KHz	-79		-82	
10 KHz	-89		-92	
100 KHz	-100		-102	
1 MHz	-110		-112	

Remote Control (Rear Panel)

Comm Port RS-485 or RS-232C, RJ-45 for Ethernet

Indicators (Front Panel)

Power On	Green LED
Mute	Yellow LED
Remote	Yellow LED
Reference	Yellow LED
Stored Fault	Red LED
Fault	Red LED

Test Points (Front Panel)

RF Sample	SMA, -20 dBc Nominal
IF Sample	BNC, -20 dBc Nominal
Optional L.O. Sample	

Power

Voltage	90 to 250 VAC Auto ranging, optional -48 VDC
Frequency	47 to 63 Hz
Dissipation	60 W

Environmental

Temperature	32 to 122°F (0 to 50°C)
Altitude	10,000 Feet MSL
Humidity	0 to 95% Relative Humidity

Physical

Dimensions (1RU) (height x width x depth)	1.75" x 19" x 22" (4.45 x 48.30 x 55.90 cm)
Weight	15 lbs (7.0 kg)

MTBF

49,740 hrs (calculated)
> 100,000 hrs. (field experience)

Summary Alarm

Relay Closure | Form C

Request A Quote