



Application

Our Low-Noise Amplifier (LNA) series includes LNAs and redundant LNA/LNB systems (C-, X-, Ku- or Ka-Band). They meet or exceed system requirements for commercial geosynchronous satellites worldwide. Their compact design and rugged construction make them ideal for transportable applications and severe environments. The LNAs have a comprehensive set of options to accommodate systems ranging from Very Small Amplifier Terminal (VSATs) to major earth stations. The redundant LNA/LNB systems include primary and backup LNA(B)s and an automatic switching controller. In case of primary LNA/LNB failure, fast automatic switchover to the backup LNA/LNB minimizes downtime.

Technology

The amplifiers incorporate both HEMT devices for low-noise temperature performance and GaAs FET devices for low intermodulation. The units use surface mounted components for robotic manufacturing techniques, thereby insuring maximum product consistency and enhanced reliability. XLNA includes integrated filtering to address adjacent power issues peculiar to demanding X-Band terminals.

Reliability

The amplifier series utilizes proprietary circuitry and high-quality components to achieve an MTBF in excess of 160,000 hours. Each unit is subjected to a 72-hour burn-in and temperature cycled from -40 to 140°F (-40 to +60°C).

Construction

The LNAs are housed in waterproof enclosures with small profiles to better accommodate redundancy configurations. The enclosures also provide a pressurizable, integral waveguide flange.

Subsystems

1+1 (one backup for one primary) and 1+2 (one backup for two primary) redundant LNA and LNB systems are available (refer to DST datasheet for available LNBs) complete with mounting plate, brackets and indoor Redundancy Controller/Power Supply (transmit reject filters, cables and other integration materials are offered as required).

Specifications

Frequency

CLNA & REDCLNA	3.4 to 4.2 GHz 3.625 to 4.2 GHz 3.625 to 4.8 GHz (45K only) 4.5 to 4.8 GHz
----------------	---

XLNA & REDXLNA	7.25 to 7.75 GHz
KLNA & REDKLNA	10.95 to 12.75 GHz 10.70 to 12.75 GHz

KaLNA & REDKLNA	19.7 to 21.2 GHz 20.2 to 21.2 GHz 17.852 to 18.588 GHz 18.372 to 19.271 GHz
-----------------	--

Noise Temperature

CLNA	30, 35, 40, 45 K
XLNA	40, 45 K
KLNA	65, 70, 80, 85 K
KaLNA	110, 120, 130, 150 K

Gain

50, 60 dB

Overall Stability (Over Temp. & Frequency)	
CLNA	± .75 dB from 3.625 to 4.2 GHz ± 1 dB from 3.4 to 4.2 GHz 0.40 dB p-p over 40 MHz

REDCLNA	± 1.5 dB over Full Band typical 0.50 dB p-p over 40 MHz typical
---------	--

XLNA	± 1.5 dB over Full Band typical 0.50 dB p-p over 40 MHz typical
------	--

REDXLNA	± 2 dB over Full Band typical 1 dB p-p over 40 MHz typical
---------	---

KLNA	± 1.5 dB over Full Band 0.75 dB p-p over 40 MHz
------	--

REDKLNA	± 2 dB over Full Band typical 1 dB p-p over 40 MHz typical
---------	---

KaLNA	± 2.0 dB over Full Band 1 dB p-p over 40 MHz
-------	---

REDKaLNA	± 2.5 dB over Full Band typical 1.5 dB p-p over 40 MHz typical
----------	---

Third Order Intercept	+20 dBm (+30 dBm opt. for XLNA)
------------------------------	---------------------------------

AM-PM Conversion	0.05°/dB @ -5 dBm (@ -10 dBm for KaLNA)
-------------------------	---

Linear Group Delay	0.01 ns/MHz (XLNA - ± .05 ns/MHz)
---------------------------	-----------------------------------

Parabolic Group Delay	0.001 ns/MHz ² (XLNA - ± .005 ns/MHz ²)
------------------------------	--

Ripple	0.1 ns p-p (XLNA - ± 1 ns p-p)
---------------	--------------------------------

Input/Output VSWR	1.25:1 Maximum (3.6 to 4.8 = 1.3:1) (1.5:1 Max Output VSWR for KaLNA)
--------------------------	--

Input Waveguide

CLNA & REDCLNA	CPR229
----------------	--------

XLNA & REDXLNA	CPR112
----------------	--------

KLNA & REDKLNA	WR75
----------------	------

KaLNA & REDKaLNA	WR42
------------------	------

Output Connector (C, X, Ku)	Type N Standard, Optional SMA
------------------------------------	-------------------------------

Output Connector (Ka)	SMA
------------------------------	-----

Operating Temp.	-40 to 140°F (-40 to +60°C)
-----------------	-----------------------------

Input Power	+12 to +24 VDC @ 120 mA
-------------	-------------------------

Power Connector	Coaxial or PTA02A-9-4P
-----------------	------------------------

System Diagrams

1:1 Redundant LNA System Block Diagram

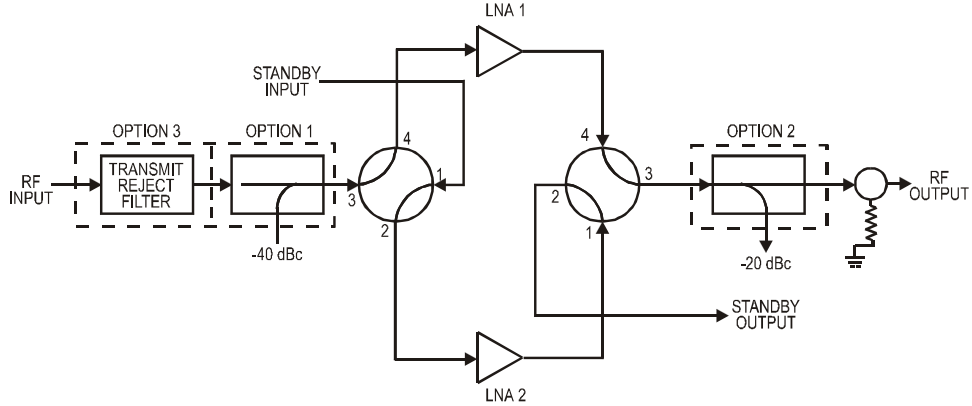

1:2 Redundant LNA System Block Diagram

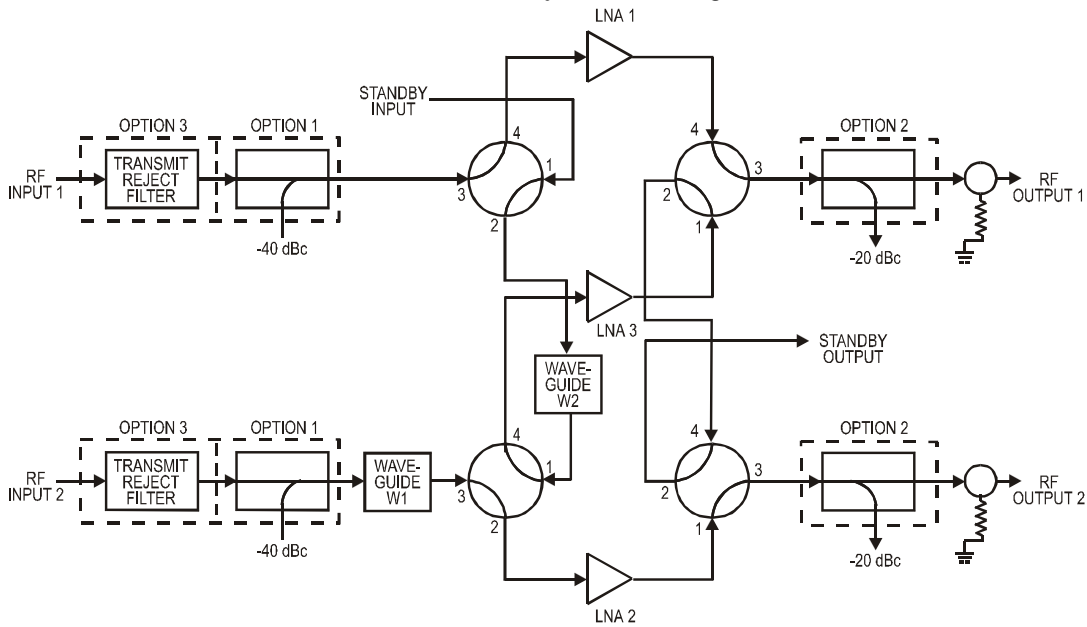

Typical System Noise Temperature Calculation

1:1 Redundant LNA System

$$T_{\text{system}} = T_{\text{LNA}} + T_{\text{SWITCH}} + T_{\text{OPTION 3}} + T_{\text{OPTION 1}}$$

1:2 Redundant LNA System

RF Input 1: LNA online signal path

$$T_{\text{system}} = T_{\text{LNA}} + T_{\text{SWITCH}} + T_{\text{OPTION 3}} + T_{\text{OPTION 1}}$$

RF Input 1: LNA 3 online signal path (LNA 1 Standby)

$$T_{\text{system}} = T_{\text{LNA}} + 2 * T_{\text{SWITCH}} + T_{\text{W2}} + T_{\text{OPTION 3}} + T_{\text{OPTION 1}}$$

RF Input 2: LNA 2 online signal path

$$T_{\text{system}} = T_{\text{LNA}} = T_{\text{W1}} + T_{\text{SWITCH}} + T_{\text{OPTION 3}} + T_{\text{OPTION 1}}$$

RF Input 1: LNA 3 online signal path (LNA 2 Standby)

$$T_{\text{system}} = T_{\text{LNA}} + 2 * T_{\text{SWITCH}} + T_{\text{W1}} + T_{\text{W2}} + T_{\text{OPTION 3}} + T_{\text{OPTION 1}}$$

Typical Noise Temperature in Kelvin at 23°C

Band (GHz)	3.62 – 4.205	3.4 – 4.2	10.7 – 12.75	Ka-Band
	WR-229	WR-229	WR-75	WR-42
TSWITCH	1.50	1.50	3.50	10.00
TW1	1.50	1.50	4.00	7.00
TW2	1.50	1.50	4.00	7.00
TOPTION1	0.50	0.50	2.00	10.00
TOPTION3	2.40	7.00	7.00	NA

Request A Quote